

Fresh Water availability and It's Global challenge

R. K. Mishra^{1*} & S.C. Dubey²

Department of Physics, Govt. Higher secondary school Kandel, dist. Dhamtari, Chhattisgarh, India

Department of Physics, S.G.S. Govt. P.G. College, Sidhi (M.P.), India

***Corresponding Author:** R. K. Mishra, Department of Physics, Govt. Higher secondary school Kandel, dist. Dhamtari, Chhattisgarh, India.

Received: 02 February 2023; **Accepted:** 07 February 2023; **Published:** 10 February 2023.

Citation: R. K. Mishra, S.C. Dubey, (2023). Fresh Water availability and It's Global challenge. Journal of Marine Science and Research. 2(1). DOI: 10.58489/2836-5933/004.

Copyright: © 2023 R. K. Mishra; this is an open-access article distributed under the Creative Commons Attribution License, which permits unrestricted use, distribution, and reproduction in any medium, provided the original work is properly cited.

Abstract

Water is prime natural resources fulfilling our needs in a precious asset. We must act to preserve and utilize every drop of water. Water resources can be assessed on the basis of surface and subsurface water bodies. Climate change impact on ground Water the impact of climate change on ground water has been studied much less than the impact on surface waters. Ground water reacts to climate change mainly due to change in ground water recharge, but also change in river level in response to increase in mean Temperature, precipitation, variability and sea level as mean precipitations. Changing land use pattern due to increasing, urbanization, industrialization and agriculture activities are serious issues that causing increase ground water withdrawal resulting in depletion of ground water resources and mining of ground water resources, along with deterioration of water quality. Rainfall is highly irregular and erratic and declining year to year due to change climatic conditions as result of serious deforestation global warming etc. Human health is affected by change in biodiversity and ecosystem. Climate change will affect the quality of drinking water and impact of fresh water availability and impact on public health. About 70% of Earth's surface is water of which 97.5% is salty water and 2.5% is fresh water. Less than 1% of this 2.5% amount of freshwater is accessible. As sea water rise's, salt water of ocean in filtrate as coastal fresh water due heavy rainfall and flooding waste more fertilizer and municipal sewage mixed with coastal fresh water and change alter into more oxygen dead zone. Weather extreme and climate variability is main driver of food production in recent global challenge. Recent global challenge food security, fresh water availability, increase incidence of extreme high sea level. Loss of agriculture reproduction and increase in food prices and changes in weather patterns and alter availability and quality of water in many parts of world. Climate change is an on-going phenomenon. This will inevitably bring about numerous environmental problems, including alterations to the hydrological cycle, which is already heavily influenced by anthropogenic activity. Chemical fertilizers have been adversely affecting the flora, fauna as well as soil quality. more ever every year plant pathogen is causing loss of 10 to 20% of agricultural production worldwide. Ground water will be vital to alleviate some of the worst drought situations. flooding and contaminated water supplies, more intense weather events are likely to increase to risk of infectious disease epidemics and erosion of low-lying and costal land. Climate Chang will affect the quality of drinking Water and impact of fresh water availability and impact on public health it's better to use UV Water purifiers. This paper will explore what climate change. Water is prime natural resources fulfilling our needs in as a precious asset. We must act to preserve and utilize every drop of water. water resources can be assessed on the basis of surface and subsurface water bodies. Climate change impact on ground Water the impact of climate change on ground water has been studied much less than the impact on surface waters. Ground water reacts to climate change mainly due to change in ground water recharge, but also change in river level in response to increase in mean Temperature, precipitation, variability and sea level as mean precipitations. Changing land use pattern due to increasing, urbanization, industrialization and agriculture activities are serious issues that causing increase ground water withdrawal resulting in depletion of ground water resources and mining of ground water resources, along with

deterioration of water quality. Rainfall is highly irregular and erratic and declining year to year due to change climatic conditions as result of serious global warming. Impacts of sea level rise on salinity intrusion global climate change has resulted in gradual sea level rise. sea level rise can cause saline water to migrate up stream in estuaries and rivers, thereby threatening fresh water habitat and drinking- water supplies. Hydrology all the costal margin; fresh ground water flowing in land areas meets with saline ground water from the ocean. the fresh ground water flows from in land areas towards the coast where elevation and groundwater level are lower because salt water has higher content of dissolved salt and minerals. it denser the fresh water, causing it to have hydraulic head than freshwater. hydraulic head refers to the liquid pressure exerted by water column. the higher-pressure density of salt water causes it to move into costal aquifers in a wedge shape under the freshwater. the salt water and fresh water meets in a transition zone where mixing occurs through dispersion and diffusion.

Keywords: *Sea level rise; climate change; salinity intrusion climate change, heat waves, extreme weather events, disaster management.*

Introduction

Earth is truly unique in its abundance Water. Water is necessary to sustaining life on earth, and help tie together the earth's lands; oceans, and atmosphere in to an integrated system. precipitation, evaporation, freezing and melting and condensation are all part of the Hydrological cycle- a never-ending process of water circulation from clouds to led, to the ocean, and back to the clouds. This cycling water is initially linked with energy exchanges among the atmosphere, ocean, and land that determine the Earth's Climate and cause much of natural variability (NRC 1999). The sun is main elements of earth climate system. the Sun is the main driver of the climate system. it's emitting Solar radiation which heats the earth and set in motion the large-scale circulation systems of the atmosphere and ocean that influence the development of weather. The amount of solar radiation received by the earth depends on the Sun's Output and is modulated by aspects of earth's orbit around the Sun. The influencing of solar activity on the global water cycle is subject of the study is the global electric circuit which is influenced both space weather and metrological factors. so, we can assume that solar activity influence on atmospheric processes by changing the parameters of the global atmospheric electrical circuit and water cycle. the ocean cover about 70% of earth's surface warm and cool more slowly than air, moderating the climate of coastal areas. the ocean currents help to distribute heat around the globe by moving warm tropical water towards the poles, and then at depth, returning cooler water back toward the equator. Water all its forms play an important and complex role in climate processes the average amount of precipitation an area receives (as rain of snow) is an important part of climate. water also helps to cost the surface (through evaporation). Reflects incoming energy from the Sun

back to Space (as clouds; snow or ice) and help to keep earth warm (as cloud or water Vapor). Global demand for fresh water was small compared with Natural flow in the Hydrologic cycle. with population growth, agriculture, However, demand for all Water related goods and services has increased dramatically, putting the ecosystems that sustain these services, as well as the humans depends on it while demands-increases, supply clean water are diminishing due to mounting pollution of inland water ways and aquifers. increasing water use and depletion of fossil ground water adds the problem. particularly important will be the challenge of simultaneously meeting the food demands of a growing population and expectation for an improved standard of living that require clean water to support domestic and industrial uses. meeting even the most basic of needs for drinking water and sanitation continues to be international development priority. Some 1.1 billion people lack access to clean water supplies and more than 2.6 billion back access to basic sanitation (WHO/UNICEF 2004). government around the world have made a commitment to reduce by half proportions of people lacking access to clean water supply and basic sanitation between 1990 and 2015. The global water cycle involves major transport link earth's atmosphere, land mass, and oceans through the emphasis in on the continental Hydrologic cycle. Natural water Cycle Powered by the Sun-Cycle of water that evaporates, condenses and precipitates on constant basis. less well-known processes include infiltration and transpiration. when precipitation falls on to a natural field or forest, much of water enters the living ecosystem; it rains on to plants, is taken by root systems and transpires into air again or remain as part of the plant. when the precipitation permeates the ground, a great deal of it percolates it to ground pocket space. our water on earth is recycled-and that

there is a limited amount of Fresh water available in the World. The water moves around Earth, it does so as part of the water cycle. Most of earth's water is present in the ocean. as the Sun shines on the water, it heats the water and causes it to evaporate. Evaporation is not only caused by heat from the Sun, But is also influenced by wind and surface area, as well as other factors: as each molecules of water on the surface area of the ocean evaporates into air, it's pulls another water molecules to the surface of water. Water molecules exposed to heat and drying effects of the air and it also will evaporate, the upward stream on inland-carried travels by current in the air(wind). as the moisture air gains elevation, the molecules become colder and condense turning in to liquid. as more and more of these water molecules condense by cluster around particles. in the atmosphere and from cloud. However, a cloud is comprised of liquid water droplets, which is can be see them, as compared to water vapor, invisible gaseous water molecules suspended in atmosphere. Construct mode and /or Visualization to more correct understanding of water cycling, especially with respect our ground water system (Dickerson,2004). 97.5 percent of water on earth is salty (National Geographic (April 2010). Two and a Half percent of earth's water is fresh, but about two-thirds of that frozen; so only about 0.8 percent of water on Earth available as Fresh water on earth available as fresh water in surface ground water. The quality and amount of water varies from aquifer to aquifer; and sometimes varies even in the same aquifer system. some aquifer can yield million of gallons of water per day, while others may yield only a very small amount of water per day. much of this variation depends upon the recharge rate of the aquifer or how fast water from the surface enters this ground water. the amount of time water spends underground also varies from aquifer to aquifer. a unconfined surface aquifer might hold water few days, weeks or more months. a deep confined aquifer may contain water that has resided underground for Hundreds or thousands-or even million-years. when precipitation falls, it infiltrates in to ground and creates a stratum of saturated earth called the Zone of sanitation. This same area is also called an aquifer. when the water can be usefully. the shape of water the table may change and vary due to seasonal changes, topography, and structural geology. seasonal fluctuations depend on the climate of a region. Water table often rises and fall around that average level.

A variety of factor affect these fluctuations, in the level of water table. the water table can also fluctuate from

the use of the ground water by people and Agriculture. as more people demand more water, they look to aquifers to provide this water. people pull the water out of the aquifer (usually through Wells), then water table will go down; if use continues to outstrip new infiltration into the aquifer, then the water-table level will be changed Permanently, which may turn affect Soil stability the hydrology. The oceans, rivers, streams, lakes, ponds, pools, polar ice caps, water vapour, etc., collectively form the hydrosphere. Hydrosphere comprises water which is an exhaustible natural resource. Water persists an liquid above 0°C and below 100°C.71% of Earth is covered by oceans which contain 97.5% of the total Water. Land contains 2.5% of the total Water. A major part (1.9% of the total) of water occurs as ice caps and glaciers. The Remaining (0.6% of the total) support total life.it is called Fresh Water (Water with salt content less than 0.5%). More than 90% of this Fresh Water is found underground as ground water. The remaining 10% fresh water occurs as surface water (rivers, dams, lakes, ponds) soil water and water vapor present in the atmosphere. Terrestrial life cannot use sea Water because Their Bodies can Neither tolerate High salt Content of the sea Water nor eliminate the salts from the Body. Water is its power to carry silt or finely divided soil in suspension this is the origin of characteristics color of water in rain feed tank. the color varies with the nature of the earth in catchment area and is most vivid immediately after a fresh inflow following rain swiftly flowing water carry really large heavy particles. The finest particles; However; remain floating within the liquid in spite of their greater density and carried to great distances. such particles are of course; extremely small, but their number is also great, and transported in this way. when sli-laden water mixes with salt water of the sea, there is a rapid precipitation of the suspended matter. This can be readily seen when travels by steamer down a great river to deep sea. the color of water changes successively from the muddy red or brown of slit through varying shade of yellow and green finally to the blue of the deep blue sea. The great tracts of land have been formed by slit thus deposited is evident on examination of the soil in alluvial areas, such land consisting as it does of finely divided matter, is usually fertile. the flow of water has undoubtedly played a great part and beneficent one in geological processes by which the soil of earth's surface has been formed from the rock of its crust. Water plays a distinctive part and wash away the soil which is foundation of all agriculture. Sudden burst of excessively heavy rain resulting in a large run off surplus water are the principal factor in causing soil

erosion. The source of availability of fresh water is rain fall.

Fresh water

Global demands for fresh water were small compared with natural flow in the hydrologic cycle. with population growth, agriculture cycle, however, demand for all water related good and service has increased dramatically, putting the ecosystems that sustain this service, as well as the humans depends on it. while demand –increases, supply clean water are diminishing due to mounting pollution of inland water ways and aquifers.

Increasing water use and depletion of fossil ground water adds the problems. particularly important will be the challenge of simultaneously meeting the food demands of a growing population and exceptions for an improved standard of living that require clean water to support domestic and industrial uses. meeting even the most basic of needs for safe drinking water and sanitation continues to be an international development priority. some 1.1 billion people lack access to clean water supplies and more than 2.6 billion lack access to basic sanitation (WHO/UNICEF 2004). Government around the world have made a commitment to reduce by half proportions of people lacking access to clean water supply and basic sanitation between 1990 and 2015. The Global Water cycle involves major transport that link earth atmosphere, land mass, and oceans through the emphasis in on the continental Hydrologic Cycle. Water supply can also be assessed from the stand point of societal access to renewable runoff and river flow, from which Human can secure provisioning services.

Ground Water

Ground water plays an important role in water supply, it has been estimated that bet ween 1.5 billion (UNEP 1996) and 3 billion people (UN/WWAP 2003). depends on ground water supplies for drinking. it also serves as the source water for 40% of self-supplied Industrial uses and 20% irrigation (UN/WWAP 2003). When rain falls, some water is lost as runoff. This water enters the rivers and seas and some of it is lost through evaporation in to atmosphere. The remaining Water percolates into the ground through the pore's spaces of the soil particles under the influences of gravity and it is available to us as ground Water. Very small pores spaces of soil serve as capillaries, allowing the water to move against the pull of gravity, water moving like this is called Capillary Water. some Water forms an extremely thin, tightly held bound with soil materials.it is known as combined Water. the

down-moving Water, called gravitational Water, finally reaches the underground water Tables, if enough rainfalls, plants can draw only capillary water from the soil. This Water is Known as available Water.

Rain Water Harvesting

Rain Water harvesting involves collection storage and subsequent use of Water deposited by rains, In water stressed, dry regions of the world, Rainwater harvesting is an ancient practice. In parts of Rajasthan, Gujrat, people collect whatever They can, the merge quantity of Water that deposited by rain, In large storage tank and vessels. This water serves them during most of the years.

In another technique of rainwater harvesting, roof tops, properly cleaned are used to collect rainwater which directed through pipes line to large underground storage Tanks which are sealed off from all sides except for a small opening used for cleaning and withdrawal purpose.

Ground Water Recharging

We can improve the ground water storage capacity of Earth's Crust by adapting the following methods.

1 collection of water deposited over roof tops, open fields and sloe by erecting impediments to check the flow.

2. directing this water to underground water table through wells, bore wells and deep shafts drilled in the soil for the purpose so that collect water goes to underground deposits quickly.

Advantages of rain Water Harvesting

The technique of the rain water harvesting has the following advantages:

1. it reduces the run-off loss of rain Water.
2. it helpful in controlling floods.
3. it maintains a supply of water during the dry months of the year.
4. it is used to raise the water table.
5. it checks soil erosion.
6. rain water harvesting recharging the ground water by throwing the rain water down in to the underground aquifers.

Conservation and management of Water Resources

In World, we often face water scarcity. The ground water level goes down in the summer seasons.as a result, during summers the municipal/corporation water supply is restricted, our wells and hand pumps become dry. such frequent situations of water crisis forced environmental biologists to seek various

means of water conservations. they have suggested following measures for avoiding misuse and wastage of portable water:

1. development of integrated water shed plan for drinking, irrigation and industrial uses.
2. Adaptation of various floods control methods.
3. Transfer of surplus water to water deficits basins by interlinking of rivers.
4. for identifying the over exploited areas of fresh water extensive hydrological surveys are done.
5. regarding avoidance of wastage and misuse of water.

Climate Change and fresh water availability

Climate change is an ongoing phenomenon. This will inevitably bring about numerous environmental problems, including alterations to the hydrological cycle, which is already heavily influenced by anthropogenic activity. The available climate scenarios indicate areas where rainfall may increase or diminish, but the final outcome with respect to man and environment will, generally, be detrimental. 1. Groundwater will be vital to alleviate some of the 2. worst drought situations. Fresh water plants are 3. important in healthy aquatic ecosystem, fresh water plant help filter the regulating some harmful chemicals. They are also a key food source for many aquatic organisms which feed them. Their leaves also capture small bits of organic matter which dragged by the water current. The organic matter or peridium sticks to their leave and stem and is afterwards consumed by fresh water shrimp.

Most of these plant species are found either partially or fully submersed in their natural habitat. Although there are a handful of obligate aquatic plants that must be grown entirely under water, most can grow fully emerged if the soil is moist. Thousands of plant species live in freshwater habitats around the world: along edges, on the surface, or at the bottom of shallow lakes and ponds; in temporarily flooded low areas and meadows; at seeps and springs (ciénegas) in hill or mountain regions; in flowing water of streams and rivers; rooted in waterlogged soils; and along any other natural or human-produced drainage system. "Freshwater wetlands" occur from below sea level to some very lofty alpine habitats, where water may persist throughout the year or where it can be very ephemeral. Normally we classify a freshwater wetland as a place where at least half of the species found there are truly aquatic plant species. Many species of aquatic plants are essentially cosmopolitan, meaning that they are widely distributed around the world. Some of the widest distributions are attributable to human activities.

Humans have accidentally transported seeds, fruits, or vegetative clones from one pond or watershed to another, but many of the cosmopolitan distributions are attributable instead to birds, particularly waterfowl, which inadvertently transport the plant propagates when lodged in their features or trapped in mud on the feet.

Climate change in particular

Change to Water quality; Quantity and availability will be an impact of ongoing Climate Change in many areas. This paper describes what Climate Change is including how it is affecting the world we live in and the time frame within which these frames within which these changes are expected to happen. Climate change needs to be a priority in development planning including the inequitable burden it places on the poor and developing countries; as well as the impact on the world's Water Resources. Climate change affect species in several way such as

1. Change in distribution
2. Increase extinction rates
3. Change in length of growing season plant.

Possible cause of Recent climate change

The change in ocean heat content was attributable to greenhouse gas-induced global warming. These anthropogenic factors. Anthropogenic factors the growing influences of human activities on the environment is being increasing by recognized, and concern over the potential for global warming caused by anthropogenic effects are growing. Climate Chang will affect the quality of drinking Water and impact of fresh water availability and impact on public health it's better to use UV Water purifiers.

Volcanic eruption and climate change

The atmospheric effects involves both micro-particles of dust as large particles rapidly settle out and gaseous Sulphur, which for sulphate aerosols. These lead to acidity in the snow falling on ice sheets and this can be measured by determined the signed of electrical conductivity in an ice core. Sulphate aerosols play as significant role by increasing atmospheric turbidity and therefore reducing the transmission of incoming solar radiation. Temperature in mid latitudes in year following major eruption are reduced average by 0.5 to 1.0 °C. it appears that repeated major eruptions are required in order to be long term climate effects.

Pollution of fresh water supplies

Pollution reduces the availability of water for Human

use. Chemical pollutant, microbial contamination, increase concentration of organic matters and elevated nitrate in drinking Water can result Health Problem. Due to this Higher Water Treatment Cost and Fresh Water Shortage are ongoing environmental problem in recent year.

Water pollution may be following three types:

1. Surface Water pollution (or inland Water pollution);
2. Underground water pollution
3. Marine water pollution.

Global water use has shown roughly an exceptional growth and been linked closely to both population growth and economic development. there was fifteen- fold increase in global water with draws between 1800 and 1980 (L'vovich and White 1990)., Global consumptive evapotranspiration through irrigation. Rising global temperature will lead to an intensification of the hydrological cycle, resulting in dryer and dry Seasons and wetter rainy seasons, and subsequently high risk of more extreme and frequent floods and drought. Changing climate will also impacts on the availability of water, as well as the quality of Water and quantity of water that is available. Melting glaciers will increase flood risk deriving the rainy season. Accessibility of water as seasonal water quantities and quality decrease as result of intensification of the hydrological cycle. Competition for available resources will intensify. Water pollution specialist have in the past failed to understand these relationship and have attempted to single out one factor as the cause of undesirable unstable algal blooms resulting from pollution (the one problem/one solution) for a while Phosphorous was favorite culprit but a ban on phosphate in detergents did not solve most problems because Nitrogen, Carbon dioxide, and many other constituents; along with Phosphorous rapidly replace one another as growth promoting factors in the translator oscillations "Blooms" of algae. There is no theoretical basis for "one-factor" control hypothesis. Physical and biological character affect man and animals. The use of fertilizer and pesticides can harm organisms living in the soil. If the soil is polluted, the ground water also gets contaminated which has adverse effect on the growth of plants and living organisms depending on it.

Water Pollution

1. Change in water quality that can harm organisms or make unfit for Human uses
2. Contamination with Chemicals
3. Excessive Heat.

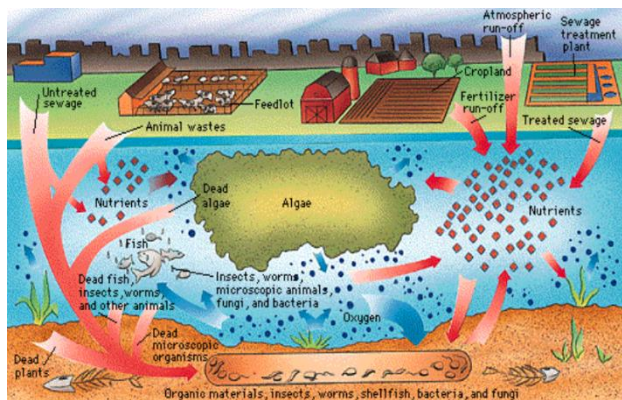

Source of Water pollution

1. Household detergents
2. Sewage
3. Industrial waste
4. Insecticides etc.
5. Oil
6. Thermal and Nuclear Power Stations
7. Infective microorganisms

Agriculture

declining crops yields. Impact on eco system changing temperature will cause ecosystems to shift- forest land types and plant species. Municipal solid waste (MSW) disposal is major global concern particularly in developing countries across the world. Rapid population growth, higher urbanization and cities have efficient waste management policies and infrastructure place land filling is the waste in low-lying areas. Ground water under flow through waste or rainwater infiltration picks up a variety of inorganic and organic compounds in organic compound such as Al, Ca, Mg, Na, Fe, Sulphate, Chlorides and heavy metals likes cadmium, chromium, coper etc. toxic metal treated from the solid waste dump's is major environmental problems in the towns and cities and pose serious contamination risk to both ground water and Surface water.

Chemical fertilizers have been adversely affecting the flora, fauna as well as soil quality. More ever every year plant pathogens are causing loss 10 to 20% of agricultural production worldwide.

Impact Human Health

higher temperature expands range of some water range of some water borne diseases. Such as Malaria, increase water borne diseases.

Impacts of sea level rise on salinity intrusion global climate change

Impacts of sea level rise on salinity intrusion global climate change has resulted in gradual sea level rise. sea level rise can cause saline water to migrate up

stream in estuaries and rivers, thereby threatening fresh water habitat and drinking- water supplies.

Global Warming

Global warming inefutably causing sea level rise. the global mean sea level raised by ~20 cm., along with rise in regional mean sea level, as the global air temperature increased by ~0.5-0.6°C during the 20th century. Sea level rise can cause saline water to migrate upstream to points where freshwater previously existed. several studies indicated that sea level rise would increase the salinity in estuaries. salinity migration could cause shifts in salt-sensitive could cause shift in salt – sensitive habits and could thus affect the distribution of flora and fauna. salinity intrusion may decrease the water become unsuitable for certain uses, such as agricultural, industrial and drinking purpose. Therefore, the determinization of the salinity distribution along an estuary is major interest for water manager in estuaries and coastal regions.

Impact on Coast Line

melting ice and thermal expansion of oceans are the key factors driving sea levels rise. Where majority of the human population live; to greater soil erosion and flooding increase rising sea levels will lead to salt water contamination of ground water supplies and threatening the quality and quantity of water.

Rising Sea levels

melting ice due to thermal expansion of ocean as result increased average temperature will result in sea levels. Sea levels have already risen between 10-20 c.m. over preindustrial averages and are expected to rise further by up to one meter during 21 Century. (According to UNFCCC report).

Flooding

in some areas; there will be increased drought leading to forest fires, increasing hospital admissions, while other release more intense rainfall will lead to mud slides, flooding and contaminated water supplies, more intense weather events are likely to increase to risk of infectious disease epidemics and erosion of low-lying and costal land.

Eutrophication

Eutrophication has created difficult problem in the vicinity of metropolitan areas and crowded resorts. Inorganic fertilizers in sewage effluent entering lakes increases their primary production rates and changes the composition of the aquatic community in ways that are not popular with public. For example, game fish such as trout, which require cool, clear, Oxygen rich

waters, may disappear; growth of algae and other aquatic plants may become so great as to interfere with swimming, boating and sport fishing; or under composed dissolved organic may purification systems. Thus, a biologically poor lake is preferable to fertile one from the standpoint of water even after it has passed through water purification system. Eutrophication is complex process which occurs both in fresh and marine waters, where certain types, where, certain types algae disturb the aquatic ecosystem and become threat for animals and human health the primarily cause of eutrophication is an excessive concentration of plant nutrient's originating from agriculture or sewage treatment. Eutrophication is the processes of excessive nutrients enrichment of waters that typically result in problem associated with microphyte algal or cyanobacterial growth (cyanobacterial also known as blue-green algae). And algae require water, carbon dioxide, inorganic substance and light for their process (Chorus and Battram 1999). Cyanobacteria are found widely in nature and flourish in water that is salty, backwater or fresh, in cold and hot springs and in environments in which no other algae filamentous forms. The growth rate of cyanobacteria is usually much lower than that of many algal species. Cyanobacteria can maintain a relatively higher growth rate compared to other phytoplankton organisms when sunlight intensities are low. They will there for have a comparative advantage in waters that turbid due to dense growths of other phytoplankton. Maximum growth rates are attained by cyanobacteria at temperature above 25°C. these optimum temperatures are higher than for green algae and diatoms (Chorus and Bartram,1991). Cyanobacteria can form floating scums (like microcystis) be distributed homogeneously throughout the epilimnion (like oscillatoria) or grow on submerged surfaces. Cyanobacteria are particularly problematic because when their cells are ruptured (e.g., by decay or by algicides they released toxic substances (cynotoxins in to water, through passive release can also occur. Ecological impacts include various water quality impacts like increased cynotoxins levels can have a number of other secondary water quality impacts.

The cause; the impact and management of eutrophication introduction ecological impact and **Human Health**

Human health impact

the word 'eutrophic' comes from the Greek word eutrophics meaning well fed. Eutrophication is the processes of nutrients enrichment of waters which results in the stimulation of an array of symptomatic

changes, amongst which increased production of algae and aquatic macrophytes deterioration of water quality and other symptomatic changes are found to undesirable. The cause; the impact and management of eutrophication. The word 'eutrophic' comes from the Greek word eutrophics meaning well fed. Eutrophication is the processes of nutrients enrichment of waters which results in the stimulation of an array of symptomatic changes, amongst which increased production of algae and aquatic macrophytes deterioration of water quality and other symptomatic changes are found to undesirable and interfere with water uses "(OECD;1982)". Eutrophication is the processes of excessive nutrients enrichment of waters that typically result in problems associated with macrophyte, algal or cyanobacterial growth. The cause and effect of eutrophication are complex. The current state of knowledge, much research work is progress that aims at furthering our knowledge of the intricate interrelationship involved in eutrophication of water resources. (Rast and Thornton 1996).

Eutrophication causes in natural lakes a distinction is sometimes made between 'natural' and 'cultural' (anthropogenic) eutrophication processes (e.g., Rast and Thornton (1996). Natural eutrophication is associated with human activities which accelerate the eutrophication processes beyond the rate associated with natural processes (e.g., by increasing nutrients loads in to aquatic ecosystems). Increased nutrients enrichment can arise from both point and non-point sources external to the impoundment as well as internal sources like the impoundment's own sediments (that release phosphate). Impact's eutrophication eutrophication is concern because it has numerous negative impacts increased productivity in an aquatic system can sometimes be beneficial Fish and other desirable animals. However, detrimental ecological impacts can in turn have other adverse impact's which vary from aesthetic ecological impacts can turn have other adverse impacts which vary from aesthetic and recreational to human health and economic impacts. Impacts of eutrophication are complex and interrelated. The excessive growth of aquatic plants and cyanobacterial have multitude of impacts on an ecosystem. the specific impacts depend on plants are stimulated to grow. Ecological impact's macrophyte invasions and algal and cyanobacterial (blue-green) blooms are themselves. Direct impacts on an ecosystem. However; their presence cause a number by other ecological impacts. Of critical concern is the impact of eutrophication on biodiversity macrophytes invasions impede or prevent the growth of other aquatic plants.

Cyanobacterial can maintain a relatively higher growth rate compared to other phytoplankton organisms when light intensities are low. They will therefore have a comparative advantage in waters that are turbid due to dense growths of other phytoplankton maximum growth rates are attained by most cyanobacteria at temperature above 25°C. Growth rates days per doubling. These optimum temperature are higher than for green algae and diatom's (Chorus and Bartam 1999). Cyanobacterial can form blooms (like microcystis), be distributed homogeneously throughout epilimnion (like oscillatoria) or grow on submerged surfaces. Cyanobacteria are particularly problematic because when their cells are ruptured (e.g., by decay or by algicides) they release toxic substances (cyanotoxins) water, through passive release can also occur. These cyanotoxins falls into three broad groups of cyclic peptides, alkaloids and lipopolysaccharides. Cyanotoxins are recognized to have caused the deaths of Wilds animals, farm livestock pets, fish and birds in many countries (Holdsworth, 1991). The primary target organ of most cyanotoxin in mammals is liver (i.e., they are hepatotoxic). Some cyanotoxins are neurotoxic (target the nerves system) and others dermato toxic (target the skin). Ecological impacts include various water quality impacts like increased cyanotoxin levels and lowering of oxygen levels (due to decay of algae and cyanobacteria). Decreased oxygen levels can have a number of other secondary water quality impacts. Anaerobic conditions allow reduced chemical species (like ammonia and sulphide) to exist. These chemicals can be particularly toxic to animals and plants.

Human health impacts: An infestation of water hyacinth (*Eichhornia crassipes*) can be a health hazard. It can provide an ideal breeding habitat for mosquito larvae and it can protect the small vector of bilharzia (Scott et al., 1979). A number of adverse consequences have been documented for swimmers exposed to cyanobacterial blooms.

Chronic exposure to low doses may promote the growth of liver and other tumors. Nevertheless, many cyanobacterial blooms are apparently not hazardous to animals (Carmichael 1992).

It is also possible exposed to odors from waterways contaminated with decaying algae or cyanobacteria may suffer chronic ill-health effects economic impacts. Human and domestic and wild animals' health impacts due to cyanotoxins in water have obvious direct economic impacts. A drinking water supply safe from cyanotoxins should be free of cyanotoxins, or have treatment in place that will

remove cyanobacterial cell (without rupturing cell (without rupturing them) and released cyanotoxins (Chorus and Bartram, 1999).

Adaptation

adaptation and development, agricultural mal-adaptation in tropical Asia. Mitigation is most cost effective and least risky strategy for reducing the future effects of climate change. Community level development such as lives and livelihoods with Nature.

Disaster management

Disaster management set of norms for each of the disaster relief team

1. Early warning and communication.
2. Evacuation and temporary shelter management team
3. Search and rescue team in local and out sides.
4. Health and first Aid team
5. Relief and co-ordination Team
6. Water and Sanitation Team
7. N.G.O., Non-governmental organization play vital role
8. Food Security Team from disaster heat area such as (low lying area)
9. Use Remote Sensing to avoiding flooding and early Warning Evacuation.
10. Distribute life support system such as medicine, drinking Water bottle. Food, Cloth, and Tent, Solar Torch or (light emitting diode) Torch, satellite phone, Generator, Radio, and mobile. First Aid Box, Candle, Blanket, Water purification Kit (instrument) which operate through Solar energy.
11. Develop and innovation Sea Water for hydrogen, is future fuel.
12. Waste Water and Garbage Treatment with proper co-ordination.
13. Revival of traditional water harvesting structure like Canal, Ponds.

Drought

Drought is a climatic anomaly characterized by deficient supply of moisture resulting either by from sub normal rainfall erratic rainfall distribution. Higher water or a combination of all factor. Prepare a broucher for an N.G.O. to create awareness about use of traditional water harvesting system. Mitigation as known as refers to any measure taken to minimizing the impact of a disaster or potential disaster mitigation can take place before during after a disaster but the term is most often used to refer to

action taken against potential disaster.

Significance of mitigation

1. Enforcing street, building codes, flood-proofing requirement
2. Construction of houses away from low lying areas.
3. Expected too unexpected.
4. Shelter, Evacuation
5. Coordinating Control NDRF Team Developed
6. Centre Chain Command.
7. Mitigation value to society, reserve ecosystem must be preserved Nature, protect entire habitats that's our mission, community participation for drinking Water Availability. Proper sanitation must, use Antibacterial Toilet most Convenient and Comfortable.
8. Mitigation creates safe communication by reducing of life and property
9. Mitigation enables individuals and communities to recovers more rapidly from disasters
10. Women play vital role, try to educate them for avoiding disaster.
11. Mitigation enables individuals and communities from disasters.
12. Enforcing street, building codes and floods – proofing requirement. Construction of house away from Hazardous areas. Pile of waste threating life. Concern waste can use local construction Ing rate 6% recycles rates.
13. Water quality complies with standards for drinking water and that is ground water are used as such as domestic consumption.
 - Effect on water pollution
 - Effect on aquatic life
 - Effect on vegetation
 - Effect on Animal
 - Effect on Human being
 - Effect on availability of drinking water and quality of water Bacterial, Virus, Protozoa.
14. Cause of Water pollution physical pollution of Water due to physical properties color odor taste turbidity thermal properties chemical pollution of water, biological pollution of water physiological pollution of Water.
15. Nuclear and Thermal power Plants repassing enormous Chemical effluent Water in to nearby agricultural fields Canal's, streams, and rivers this results adversely effects on the Human beings, plants, animals, vegetation, Soil Water and

increasing pH, TSS, and TDS.

16. In many areas over-irrigation and excessive use of these Chemical fertilizer, monoculture type of cropping pattern have started adversely affecting the Soil quality. The quantity and quality of crop production depends on physical, Chemical and biological properties of Soil Fertility plays a key role in increasing crop production the large quantities of chemical fertilizer, pesticides and insecticides used to enhance crop yield.

17. Changing land-scape pattern due to increasing, urbanization, industrialization and Agricultural activities are serious issue that causing increase ground Water withdrawal resulting in depletion of ground Water resources and mining of ground Water resources along with deterioration of Water Quality. Rainfall is highly irregular and erratic and declining year to year due to change climatic conditions as result of serious deforestation global warming etc.

Characteristics of a Freshwater Environment

Estimate of Global Water Distribution	Volume (1000 km ³)	% Of Total Water	% Of Fresh Water
Oceans, Seas, and Bays	1,338,000	96.5	-
Ice Caps, Glaciers, and Permanent Snow	24,064	1.74	68.7
Groundwater	23,400	1.7	-
Fresh	(10,530)	(0.76)	30.1
Saline	(12,870)	(0.94)	-
Soil Moisture	16.5	0.001	0.05
Ground Ice and Permafrost	300	0.022	0.86
Lakes	176.4	0.013	-
Fresh	(91.0)	(0.007)	.26
Saline	(85.4)	(0.006)	-
Atmosphere	12.9	0.001	0.04
Swamp Water	11.47	0.0008	0.03
Rivers	2.12	0.0002	0.006
Biological Water	1.12	0.0001	0.003
Total	1,385,984	100.0	100.0

Source: Gleick, P. H., 1996: Water resources. In *Encyclopedia of Climate and Weather*, ed. by S. H. Schneider, Oxford University Press, New York, vol. 2, pp.817-823.

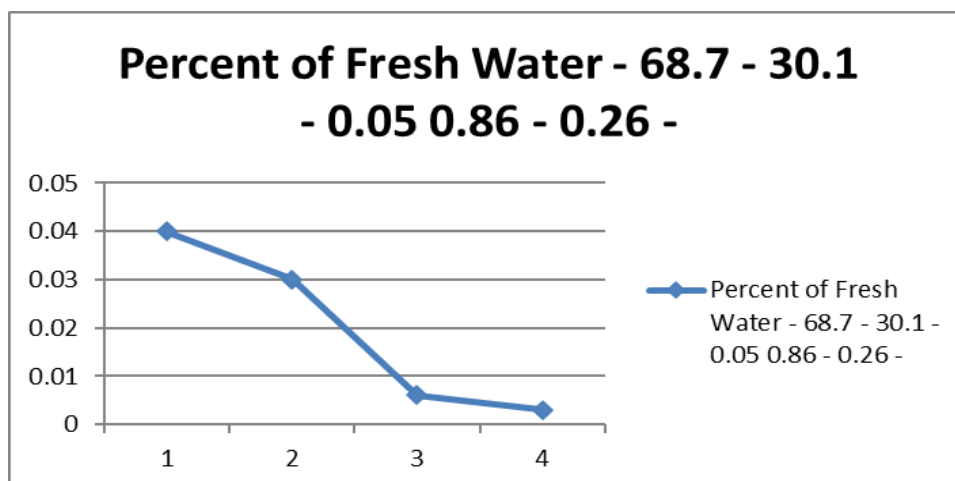

Fig 1A: Percent of Fresh Water

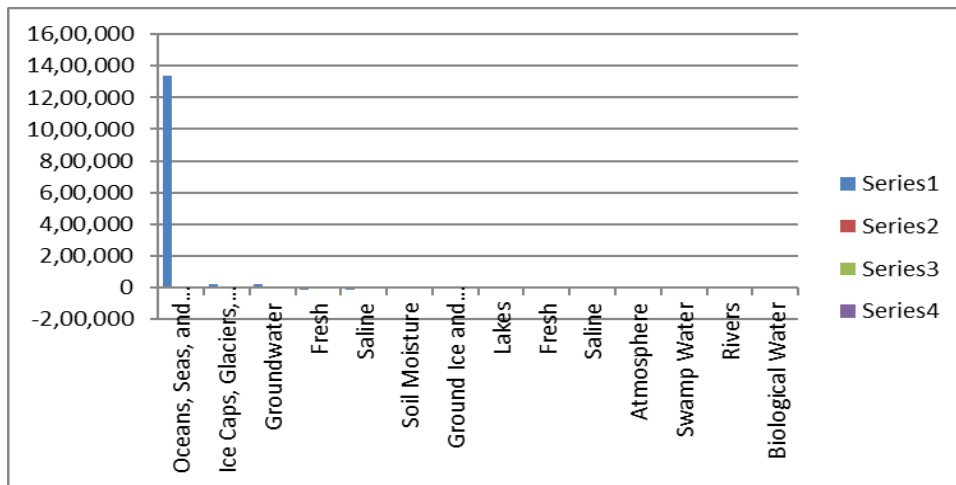
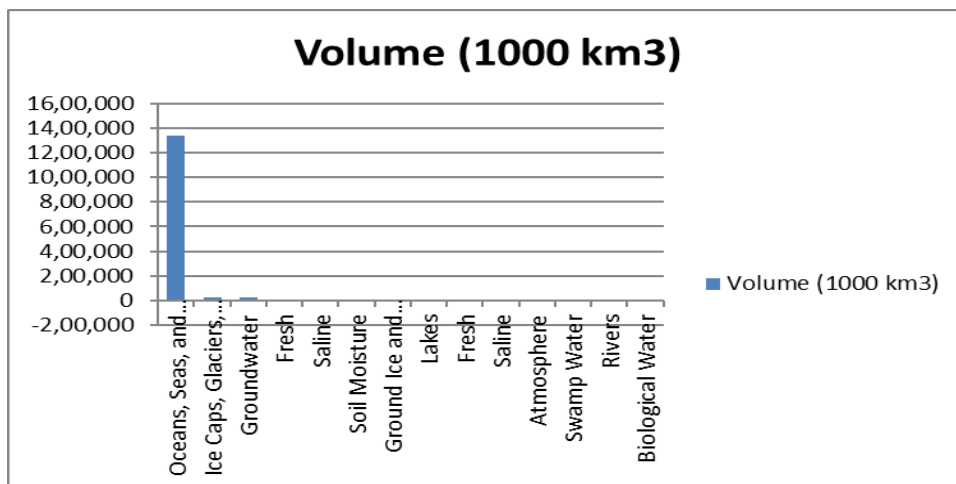

Figure 1(a) and Figure 1(b) shows percent fresh Water Table.



Volume

The effect of Eutrophication on Drinking Water

The effects of eutrophication on the environment may have deteriorate consequences of health of exposed animal and human populations through various path ways. when fresh water, extracted from eutrophic areas, is used for the production of drinking water severe impacts can also occur during watering in eutrophic waters. eutrophication is complex processes which occurs both in fresh and marine waters, where certain types of algae disturb the aquatic ecosystem and become a threat for animals and human health the primary cause of eutrophication is an excessive concentration of plant nutrient's originating from agriculture, sewage treatment. The main cause of eutrophication is the large input of nutrient mixed to water body and the main effect is imbalance in the food web that results in the high levels of phytoplankton, zooplankton, algae biomass in stratified water bodies. This can lead algal blooms. The direct consequences is in an excess of oxygen consumption near bottom of the water body. eutrophication processes can be divided in to two categories depending on weather they are

linked to the nutrient's dispersion and phytoplankton growth to oxygen cycle near the bottom of the water body. Various effects can be observed depending upon the severity of the eutrophication. Treatment of eutrophic water for producing drinking water. algae disturb the aquatic ecosystems a threat for animal and human health. Eutrophication concerns the availability of oxygens. Some species of algae may also contain toxins but incidents where fresh water algae or the origin of cause human or animal illness. Some cyanobacteria have capacity to produces toxins dangerous to human beings. A variety of symptoms depending on toxins implicated our observed such as fatigues, headache, diarrhea, vomiting, and some throat fever skin irritations. Good practices to inform people about risks of bathing or sporting activity in normally colored or turbid waters. Allergic bathers of people walking along shore of water body affected by algae blooms. Any allergies releasing not only toxin but also allergic compounds. In some specific case; local authorities must rely on eutrophic water for producing drinking water. Water is plentiful, at least during the growing season.

Wavelengths of sunlight used for photosynthesis is low for submerged leaves, because light penetration through the water column is very much reduced. At the water surface there often is unobstructed full sun for a photosynthetic organ floating and an emergent can occupy may intercept high photosynthesis. Concentration of carbon dioxide dissolved in water is low (higher in water strongly acidic or strongly basic than in neutral pH solutions). Oxygen concentration of oxygen in the water and in thick tissues of the underwater plant is low. Minerals and nutrients are scarce or dilute within the water medium, as compared with drier soil.

Water best drink to fight the heat.

Water circulates through the water cycle in three form- solid, liquid and gas. 97.4% of total available Water is in the sea and Ocean which cannot be directly used by us because of high salt content rate. Only 0.01% water on earth is available to us. Ground water is an important Source of Fresh Water for us. Pollution of Source of Water Such as Rivers, lakes and ground water has resulted in deterioration of the quality of water available to us. Uncontrolled extraction of ground water farmers has over-exploited ground water using borewells, tube wells etc. this has led to depletion the water table. Polluting of fresh water due to the discharge of untreated Sewage from homes toxic chemicals from the industries and pesticides which are drained in to nearby water bodies, polluted water is unfit for consumption. Poor water conservation not much effort is being taken to preserve water.

Treating sewage and factory waste.

Define acceptable levels of confidences (risk), and Cost providing adequate supplies of clean Water over a specified time period. Select and implement Water-Supply/Water treatment/Water distribution and Water conservation/water Reuse projects. Evaluate the needs to existing policies, regulations and Management strategies. The less desirable alternative to sound planning and management is to adopt a "Wait-and-see" and contingency" strategy to find out what or not existing Water supply facilities can cope the next major drought and economic growth as they occur. Concentration of carbon dioxide dissolved in water is low (higher in water strongly acidic or strongly basic than in neutral pH solutions). Oxygen concentration of oxygen in the water and in thick tissues of the underwater plant is low. Minerals and nutrients are scarce or dilute within the water medium, as compared with drier soil.

Moving water (currents and waves) can be damaging

to the organs of the plant. A number of floating aquatic species are excellent organisms in which to study logarithmic population growth. Under full sun and non-limiting nutrients, a single individual can be introduced into a pond and multiply rapidly via vegetative means. Water-lettuce, *Pistia stratiotes*, forms new plants around the mother plant via underwater stolen. Water-hyacinth, *Eichhornia crassipes*, and floating fern species of *Salvinia* and *Azolla* also show explosive population growth. In the tropics and heated quiet waters of ponds and lakes, such species can completely cover the water surface within several months, and for that reason are considered pernicious aquatic weeds, which are removed at great expense and trouble because they clog channels and choke out other forms of life in the body of water.

97% of water on the Earth is salt water, and only 3% is fresh water of which slightly over two thirds are frozen in glaciers and polar ice caps. The remaining unfrozen fresh water is mainly found as groundwater, with only a small fraction present above ground or in the air. Fresh water is a renewable resource, yet the world's supply of clean, fresh water is steadily decreasing. Water demand already exceeds supply in many parts of the world and as the world population continues to rise, so too does the water demand. Awareness of the global importance of preserving water for ecosystem services has only recently emerged as, during the 20th century, more than half the world's wetlands have been lost along with their valuable environmental services. Biodiversity-rich freshwater ecosystems are currently declining faster than marine or land ecosystems. The framework for allocating water resources to water users is known as water rights. Recent 3.5 million deaths a year from water-borne diseases while also cutting emissions of the greenhouse gas carbon dioxide. The vast majority of the Earth's water resources are salt water, with only 2.5 being fresh water. Approximately 70% of the fresh water available on the planet is frozen in the icecaps of Antarctica and Greenland leaving the remaining 30% available for consumption. From this remaining 0.7%, roughly 87% is allocated to agricultural purposes (IPCC 2007). According to the Comprehensive Assessment of Water Management in Agriculture, one in three people are already facing water shortages (2007). Around 1.2 billion people, or almost one-fifth of the world's population, live in areas of physical scarcity, while another 1.6 billion people, or almost one quarter of the world's population, live in a developing country that lacks the necessary

infrastructure to take water from rivers and aquifers. Water of hydrogen cycle -80-90% availability water, in earth 75% water are available. In hydrosphere in 14 million cubic kilometer water are available. 97% availability of sea water, 3% available of fresh water. 22.4% available water in ground water. Only 4% of water available in ponds and rivers.

Water Source	% Of Total Water on Earth
Oceans	97.2
IceCaps/Glaciars	2.38
Ground Water	0.397
Surface Water	0.222
Atmosphere	0.001

Standard atmospheric processes and the water Cycle-Earth systems have internal and external

sources of energy, both of which create heat driven by sunlight and earth's internal heat, a variety of cycles connect and continual circulate energy and material through the components of the earth systems

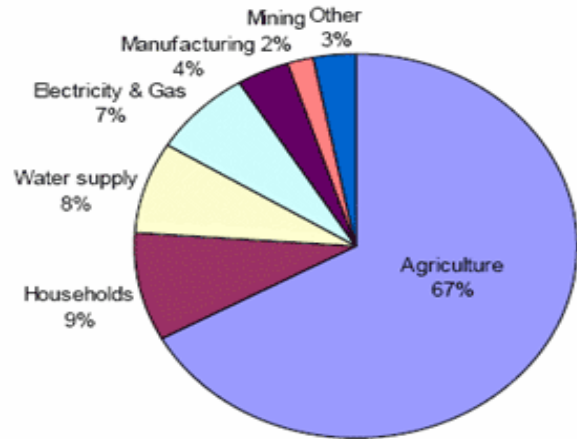
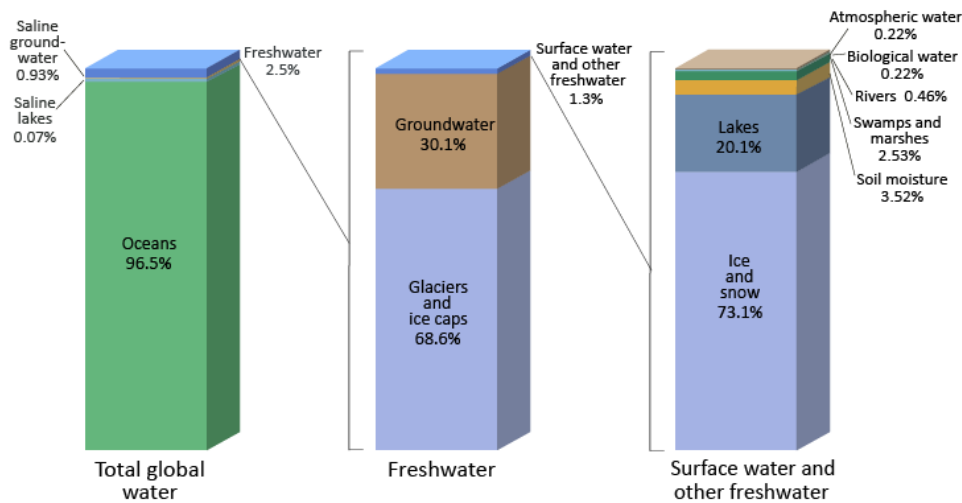

Fig 2: Water use in the world (2011)

Distribution of Earth's Water



Source: Igor Shiklomanov's chapter "World fresh water resources" in Peter H. Gleick (editor), 1993, Water in Crisis: A Guide to the World's Fresh Water Resources.

Fig 3: Graph fresh water availability

There are four main factors aggravating water scarcity according to the IPCC:

1. Population growth: in the last century, world population has tripled. It is expected to rise from the present 6.5 billion to 8.9 billion by 2050. Water use has been growing at more than twice the rate of population increase in the last century, and, although there is no global water scarcity as such, an increasing number of regions are chronically short of water.
2. Increased urbanization will focus on the demand for water among a more concentrated population. Asian cities alone are expected to grow by 1 billion people in the next 20 years.

3. High level of consumption: as the world becomes more developed, the amount of domestic water used by each person is expected to rise significantly.

Climate change will shrink the resources of freshwater.

Melting Glaciers

Tibet Glaciers melting due to pollution: Chinese Scientist Beijing, Mar 25 (PTI) about 90 percent of glaciers in Tibet called the third Pole region, are shrinking because of black Carbon pollution "transferred from South Asia" to the Tibetan Plateau, Chinese Scientist has Warned. Thei third pole region,

which is centered on the Tibetan plateau and concerns the interests of the surrounding countries and region, covers more than five million square kilometers and has an average altitude of more than 4,000 meters. Like Antarctica and arctic, the Third pole is drawing increased attention from the international academic Community, but the results of former international studies in this area are inconsistent, Yao Tandong, Director of the Chinese Academy of Science Institute of Tibetan Plateau Research said. The area has the largest number of glaciers outside the polar region and exerts a direct influence on the social and economic development of some of the most densely populated regions on earth, including China and India. The glaciers are at the head waters of many prominent Asian Rivers. Influenced by global warming, its alpine glaciers have seen drastic changes in recent years. Such as thinning and Shrinkage, which pose potential geological Hazards to people both on and around the plateau. Ongoing research over more than 30 years has also given Scientists a new understanding of pollution on the Tibetan plateau, Yao said claiming that most of the pollution were coming from south Asia. Latest investigations now show that black Carbon generated from industrial production in south Asia is being taken to the Tibetan Plateau by the Indian monsoon in spring and Summer, he said in a report in state-run China Daily. The accumulation of Black Carbon on the plateau will accelerate the shrinking of glaciers, bringing with it persistent organic pollution that will be deposited in the soil.

Food Security

the predicted changes in the quantity, quality and accessibility to water will have important consequences for human populations, through impacts to agriculture and food security, health, economic activity and conflict over water resources. Food is basic need and every citizen of the country should access to food which provided minimum nutritional level.

Coping with water Scarcity

Water Scarcity problems generated primarily by summer heat waves and long periods of drought. The high temperature excessive evaporation and scant precipitation have negative impact on water resources. (Alina Cocos. Octavina Cocos et al 2011.) small amount of water comes from rivers as well as pond's which used by local people to water their crops the water used for covering domestic, public and industrial consumption comes from underground sources. Then going pressure on ground water's,

which often is greater than the recharge capacity of the aquifers, confirms the existence of Water-stressed territory. With scarcity index of 0.7-1 suggesting that water scarcity index suggesting that water Resources are heavily exploited. (Water Scarcity index 2007.)

Water and Climate Change

The quality of water supplies will become a further concern in some region of the globe. Water acquires most of its geochemical and biochemical substances during cycles from clouds to rivers through the biosphere, soils and geological layers. Climate changes the amounts or pattern of precipitation will change the route/residences time of water in the water shed, there affecting its quality; as result, regarded less of quantity, water could become unsuitable as resources if newly-acquired qualities make it unfit for required use. ("Climate change the water rules" page 16-17)

Water scarcity is expected to become an ever-increasing problem in the future, for various reasons. First, the distribution of precipitation in space and time is very uneven, leading to tremendous temporal variability in water resources worldwide (Oki et al, 2006). For example, the Atacama Desert in Chile, the driest place on earth, receives imperceptible annual quantities of rainfall each year. On the other hand, Mawsynram, Assam, India receives over 450 inches annually. If all the freshwater on the planet were divided equally among the global population, there would be 5,000 to 6,000 m³ of water available for everyone, every year. Second, the rate of evaporation varies a great deal, depending on temperature and relative humidity, which impacts the amount of water available to replenish groundwater supplies. The combination of shorter duration but more intense rainfall (meaning more runoff and less infiltration) combined with increased evaporation and plant transpiration from the earth's land surface to atmosphere and increased irrigation is expected to lead to groundwater depletion (Konikow and Kendy 2005).

Water Borne Infectious diseases

Water Borne diseases caused by consumption of water contaminated by Human or Animal waste and containing pathogenic parasites, Bacteria, or Viruses. they include the diverse group of diarrheal diseases as well as cholera, typhoid; and amoebic Dysentery, these diseases occur to safe drinking water for Basic Hygiene; and most could be prevented by treating water before use. the world health Organization estimates that there are 4 billion cases of diarrhea

each year in addition to millions of other cases of illness associated with lack of access to safe water (WHO/UNICEF 2000). this translates into 1.7 million death per years, mostly among Children under the age five (WHO 2004). Water- washed diseases are caused by poor personal Hygiene and skin or eye contact with contaminated water; their incidence is associated with lack of access to basic sanitation and sufficient water for effective Hygiene (Bradely,1977; Gleick 2002; Jensen et al.2004). These include scabies, trachoma, and flea. TOrachoma alone estimated to cause blindness in 6 million people (WHO/UNICEF2000).

water-related vector-borne diseases are caused by parasites that require a vector (such as Insects) to develop and transmits the disease to Humans for example; Anopheles Mosquitoes are the vectors for a Protozoan parasite (Plasmodium that cause malaria. these diseases are strongly related ecosystems – linked, in contrast to other three categories of water-related diseases, where water quality is determinant. Anopheles Mosquitoes-vectors of malaria (1.3 million death a Year). annual barden of over 46 million dollars.

Water-washed diseases are caused by poor personal hygiene and skin or eye contact with contaminated water; their incidence is associated with lack access to basic sanitation and sufficient water for effective Hygiene (Bradely,1977; Gleick 2002; Jensen et al. 2004). these include scabies trachoma, and flea, lice and risk-borne diseases, Trachoma, alone estimated to cause blindness in 6 million people (WHO/UNICEF 2000).

Chemical Pollutions

Another set of diseases affecting industrial and developing nations a like arises in response to chemical pollution of water by heavy metals, toxic substances and long-lived synthetic compounds. While evidence of the long-term impacts of chemical pollution can be detected even in the remote Arctic (AMAP 2002). impacts on poor's populations in developing countries are difficult to identify However, exposure to chemical agents in water has been related to a range of chronic diseases develop over several years, making the links between cause and effect difficult to establish on global scale, the burden of diseases from chemical pollution is much lower than from microbial contamination and parasites diseases, but in some highly polluted regions the risk. Can be substantial (WRI et al 1998).

exposure to chemical pollutants can also compromise the immune systems, rendering people

more susceptible to microbial and viral infections. Naturally occurring inorganic pollutants constitutes a class of chemical pollution with serious long-term health effects. Arsenic which occurs naturally in some soils, for example; can become toxic when exposed to atmosphere, as seen in areas with high water abstraction from underground aquifers (WRI et al 1998). Aresenicosis is the result of arsenic poisoning from drinking arsenic –rich water over long periods of time and great concern in many countries; including Argentina, Bangladesh, China, India, Mexico, Thailand and United State (Bonvallot 2003.). WHO estimate in 2001 that Bangladesh alone 35-77 million people-close to half the population-were exposed to drinking water from deep wells contaminated with high levels of arsenic? Arsenic is carcinogen liked to skin, lung, and kidney, cancer although these diseases can go undetected for decades (WRI et al.,1998); in other parts of the world, high fluoride concentration in drinking water have resulted in long term effects that weaken to skelton. long term lead poisoning from old water pipe line, for example, can cause significant neurological impairment (WRI et al.1998). mercury contamination can also originates from industrial discharge and runoff from mining activities; accumulating in animals tissue, particularly fish (WCD 2000).

Water Quality

Freshwater bodies have a limited capacity to process the pollution stemming from expanding urban, industrial and agricultural uses. Water quality degradation can be a major source of Water scarcity. Although the IPCC projects that an increase in average temperatures of several degrees as a result of climate change will lead to an increase in average global precipitation over the course of the 21st century, this amount does not necessarily relate to an increase in the amount of potable water available. A decline in water quality can result from the increase in runoff and precipitation- and while the water will carry higher levels of nutrients, it will also contain more pathogens and pollutants. These contaminants were originally stored in the groundwater reserves but the increase in precipitation will flush them out in the discharged water (IPCC 2007). Similarly, when drought conditions persist and groundwater reserves are depleted, the residual water that remains is often of inferior quality. This is a result of the leakage of saline or contaminated water from the land surface, the confining layers, or the adjacent water bodies that have highly concentrated quantities of contaminants. This occurs because decreased precipitation and runoff results in a concentration of pollution in the

water, which leads to an increased load of microbes in waterways and drinking-water reservoirs (IPCC 2007). One of the most significant sources of water degradation results from an increase in water temperature. The increase in water temperatures can lead to a bloom in microbial populations, which can have a negative impact on human health. Additionally, the rise in water temperature can adversely affect different inhabitants of the ecosystem due to a species' sensitivity to temperature. The health of a body of water, such as a river, is dependent upon its ability to effectively self-purify through biodegradation, which is hindered when there is a reduced amount of dissolved oxygen. This occurs when water warms and its ability to hold oxygen decreases. Consequently, when precipitation events do occur, the contaminants are flushed into waterways and drinking reservoirs, leading to significant health implications (IPCC 2007).

Water quality is defined by its desired end use. Water for recreation, fishing, and drinking and habitat for aquatic organisms thus this reason, water quality takes on broad definition as the "physical, chemical, and biological characteristics of Water necessary to sustain desired water uses (UN/ECE 1995). Many chemical, physical, biological; and societal factors affects water quality: organic loading (such as Sewage); Pathogens, including Viruses in waste streams from Humans and domesticated animals; agricultural runoff and Human waste laden with Nutrients (such as Nitrates and Phosphates) that give rise to eutrophication and oxygens. stress in water ways; salinization from irrigation and water diversions; Heavy metals; Oil pollution; plastics and pesticides, medical drugs residues and hormone mimetics and their by – products; radioactive pollution; and even thermal pollution from industrial cooling and reservoir operations. Furthermore, despite important improvements in analytical methodologies (UN/ECE 1995; Meybeck 2002), The capacity to operationally monitor contemporary trends in water quality is even more limited than monitoring the physical quantity of Water. Natural water chemistry is inherently highly variable over space and time (Meybeck and Hemler 1989; Meybeck 2003), and aquatic biota are adapted to this variability with added pressure from Human activities, the biological state of inland waters plus their variability is altered, often to the detriment of aquatic species, thereby compromising the sustainability of aquatic ecosystems. Many physical, biological, and societal factors affects water quality: organic loading (such as Sewage); Pathogens, including Viruses in waste streams from Humans and domesticated animals;

agricultural runoff and Human waste laden with Nutrients (such as Nitrate and Phosphate) that give rise to eutrophication from irrigation and water diversions, heavy metals; oil pollution, salts, such as plastics and hormone mimetics and their byproducts; radioactive pollution; and even thermal pollution from Industrial Cooling and reservoir operations.

Population growth and development

population growth is major indirect driver of change in the provision of fresh water. Although fresh water supplies are renewed through more or less stable global water cycle that produces precipitation in excess of evapotranspiration over the continents, the mean quantity of water supply available per capita is ever-decreasing due to population growth and expanding consumptive use (Shiklomanov and Rodda, 2003). Human population doubled from 1960 until the present (Cohen 2003), and nearly 20 contemporary cities are home to 10 million people or more (Cohen 2003). Substantial flow stabilization and increased withdrawals have occurred across all regions; supporting and increase in number of people sustained by the accessible, renewable water supply. Over the twentieth century of declining per capita supplies over the twentieth century, water withdrawals increased by factor greater than six—more than twice the rate of population growth (WHO 1997). Pollution from Industry, Urban Centers, and agricultural runoff limits the amount of surface and ground water available for domestic use and food production. Threat of water quality degradation are most severe in areas where water is scarce because the dilution effects is inversely related to the amount of water in circulation.

Effects on Coastal Populations

For coastal populations, water quality is likely to be affected by salinization, or increased quantities of salt in water supplies. This will result from a rise in sea levels, which will increase salt concentrations in groundwater and estuaries. Sea-level rise will not only extend areas of salinity, but will also decrease freshwater availability in coastal areas. Saline intrusion is also a result of increased demand due in part to growing coastal populations that leave groundwater reserves increasingly vulnerable to contamination and diminishing water reserves (IPCC 2007). Rise sea levels will also lead to salt water contamination of ground water supplies threatening the quality of fresh water access to large percentage of population (reference- "Stern Review Chapter3).

Recommendations and Suggestions

1. Pollutants are produced by natural ecosystems

as well as by man's agricultural and industrial activity, however nature by and large "threats" (that is, renders less harmful), recycles, or makes good use of pollutants.

2. Protect biodiversity, protect conserve forest and natural habitats for wild animal
3. Society and research institution play vital role to protect fresh water availability and natural water resources such as pond, ground water, lake and river's
4. Promote use Bio-Pesticides and Bio-fertilizer, ban on chemical fertilizer and insecticides pesticides, ban detergents which contaminated ground water, promote organic fertilizer and Vermi- Compost.
5. Control population due to over population we suffer from food crises, fuel crises, urban crises and drinking water crises.
6. Protect from people nuclear disaster because nuclear disaster harmful for human, flora and fauna contaminated our ground water and natural water resource such as pond, lake, river
7. Promote clean energy resource, wind, solar energy, Geothermal energy, bio- fuel, and tidal energy.
8. Polluting control at industries resources, community development for water availability in village area.
9. Preparation of water quality map water quality monitoring. Use remote sensing water map.
10. The waste water must be treated before discharge into lake or river this limit its nutrient input
11. Adaptation of new techniques to preventing soil erosion will help to conserve and keep the water where it is wanted. Seasonal rainfall an immense quantity of brain water must necessarily runoff the ground. The collection of water and proper utilization is more importance.
12. Water purification treatment plant and ban on illegal mining at bank of river. River Sand is necklace of river which storage the water seepage and passes through at underground and enhance water level.
13. Prepare useful work of waste assimilation and recycling worth many dollars is accomplished.
14. Less car dependence, less emission, promoting bicycle and greener mobility
15. Fully utilizing public road transportation system, Collective intelligence, smoother transportation.
16. Promote waste water treatment facilities in Gas and oil development
17. Serve energy with Alternative energy from clean

energy

18. Check water Quality at home. And reduce water leakage rate, water quality use for poor, water clean and Bacterial free drink with tap water, tap water taste are good., tape water is safe for drinking.
19. Provide World wide fund for Ganga Action plan to clean River Ganga and make it pollution free.
20. The WWF for nature found that Ganga is one of the most endangered rivers in the World. Ganga is the most famous river of India Million's people depends on it for their daily needs and livelihood but at present the water of rivers ganga has been excessively polluted the course the river, dispose of large quantities of Garbage, untreated sewage dead bodies and many other harmful things directly into rivers. the rivers is dead at many places where pollution levels are so high that aquatic life cannot survive.
21. Use Cloth bag or jute bags are biodegradable and hence environment friendly whereas plastic and polythene is nondegradable.
22. The Predicted changes in the quantity, quality and accessibility to water will have important consequences for human populations, through impacts to agriculture and food security, health, economic activity and conflict over water resources. Food is basic need and every citizen of the country should access to food which provided minimum nutritional level.
23. River expert says that main river pollution level based on river if distributary river cleaned. automatically main river free from pollution.
24. Use of manure and organic pesticides should be encouraged.
25. Industrial waste should be treated, before being released in to river
26. Applying organic farming such as Vermi-compost's use of manure and organic pesticides should encouraged.
27. Improper dumping of waste and sewage can pollute Soil and ground water.
28. The use of excessive use of fertilizer and pesticides can harm organisms of lining in the soil. If soil is polluted; the ground water also gets contaminated which has an adverse effect on growth of plants and living organisms depending on it.
29. 97.4% total available water is in the seas and oceans which cannot be directly used by us. Because of it high Salt content. Only 0.01% of water on earth is available to us for consumption.
30. Water makes up about 60% of our body weight. Every system of our body depends on water. Water

flushes toxins out of vital organs, carries nutrients to cells and provides a moist environment for ear, nose and through tissues. Lack of water can lead to dehydration, a condition that occurs when don't have enough water in our body to carry out normal functions. Even mild dehydration can drain our energy and make tired.

31. Stev Verma, director, Beltek Candian Water Limited, which makes Vitamin enriched Water drink, Wild Water:" our product is a natural alternative to colas and an exciting alternative to normal packaged water."

32. Water is not "food" but water Crucial when it comes to skin health because it flushes toxins out of the body, delivers nutrients to cells, and keeps organs functioning. It also helps keep cell pumps and full, which makes the skin look firmer and clearer.

33. According to American NGO institute of medicine, an adequate intake for men is roughly three liters of beverages a day. For women it is 2.2 liter of beverage a day.

34. Adaptation: adaptation and development, agricultural mal-adaptation in tropical Asia.

35. Mitigation is most cost effective and least risky strategy for reducing the future effects of climate change.

36. Community level development such as lives and livelihoods with Nature.

37. Shared development goals need to be determined if adaptation is to be sustainable.

38. Supporting NGO coalition for climate Change; link with local isolated group and organization will struggle to make their Voice Heard at national and international levels.

39. Right to water clarify the legal entitlement to access Water resources for all users.

40. Developed community ponds to irrigate surrounding land, provide water sources and options for fish cultivation. Built check Dam are small designed to delay the flow of water of rain water so it has time to soak in to the earth and replenish the ground water table while keeping adjacement and moist.

41. Development of alternative cropping patterns, use of drought resistant crop which require less water input and hence have less impact on water tables.

42. Raised Hand Pumps to protect drinking Water from flood contamination.

43. Use Remote sensing for search for water and flooded area of river.

44. Remove heavy metal from water such as iron,

arsenic, fluorine., remove from Kent Mineral RO water Purifiers (house of purity)., which use RD+UF+TDS method= multi purification system+ pure water of 0% wastage.

45. Rapid melting of Arctic will have major impact on India.

46. There is problem of Water-hyacinth (Eichnornia) Hydrophytes which is clean the river. Water hyacinth can used as to make Mat, Bag, file cover and dining table cover to replacement of polythene in cities. (by local Villager of Jurihiya,Dist Jalandher Punjab).

47. In U.S.A. water foot print 2500 cubic meter per year. Largest consumption due to nonvegetarian people the U.S.A. people. Use U.S.A. Person water in nonvegetarian food is 5 cubic meter. Development countries Waste Water and consumption more.

48. Boosted clean energy industries

49. Use Nuclear guideline

50. Avoid toxic pollutant spreading. Which polluted in ground water. Chemical Toxic, mercury, heavily metals pesticides are main pollutant which polluted ground water.

51. Adaptable eco- friendly technology and innovation it.

52. Action plan for waste water / garbage management has four stage 1. Recycle2. Reuse (plastic, paper glass, wood, glass metal) 3. Reduce (garbage generated should be reduced to minimum) 4. Refuse all those items which pollute environmental are not required and cannot be recycled should be avoided.

53. Updating Environmental Law

54. Conservation biological diversity

55. Population stabilization.

56. Recycling waste and residue.

57. Avoid War, War is not common solution, war can pollute water, Soil, and air pollution but Air pollution mostly, heavy metal from air pollution mixed with food, and water can create birth defect in child.

58. One Problem and One Solution approach,

59. Agriculture is the biggest water user so proper utilization of water is needed in practice. Stop wastage of water in domestic propose.

60. Promote community development of water availability and promote the use of water effective technology in practices.

61. Protect biodiversity; protect conserve forest and natural habitats for wild animal. Promote biogenic resources.

62. Society and research institution play vital role to

protect fresh water availability and natural water resources such as pond, ground water, lake and river's

63. Promote use Bio pesticides and Bio fertilizer, ban on chemical fertilizer and insecticides pesticides, ban detergents which contaminated ground water, promote organic fertilizer and vermicompost.

64. Change Human behavior and public attention, Conserved Rain Water, Promote rain water harvesting, protect and build ponds in village area to increase ground water.

65. Control population due to over population we suffer from food crises, fuel crises, urban crisis and drinking water crisis.

66. Protect from people nuclear disaster because nuclear disaster harm full for human, flora and fauna contaminated our ground water and natural water resource such as pond, lake, river

67. Conserve Energy resources by reducing, and recycling waste and increasing efficiency of use of waste.

68. Fellow Dharma of ecology according to Dr. T. N. Khashoo put new concept Dharma of ecology the only way to meet the challenge from common threat to our long-range ecological Security

69. Global ethics or dharma of ecology starting from individual to meet this threat to our environment

70. Protecting and augmenting regenerability of life support system.

71. Protecting renewable resources and conserve non –renewable resources and avoiding waste, ex-. solid and chemical waste

72. Promote clean energy resource. Such as Wind, Solar, Hydrogen, Nuclear Energy.

73. Pollution control at Carbon, Capture tree. Plant it... Promote Carbon absorbing tree such as Babool (Acacia Senegal) and Oxigen emitting plant such as Peepal, Neem (Ajericta indica), Bail, Banayan (Ficus Religiosia).. and Amala tree (Embluca officinalis), Ashoka (Saraca indica), Bell (Aegal Indica) which has lot capacity of produce oxygen 1800kg/hour.

74. Polluting control at industrial resources

75. Environmental planning guides., protecting drinking water, and water resources

76. Coastal sea water management long term measure

77. Pollution or flood control Program me are to be plan for river basin.

78. Preparation of water quality map water quality monitoring.

79. The waste water must be treated before discharge into lake or river this limit its nutrient input

80. Adaptation of new techniques to preventing soil erosion will help to conserve and keep the water where it is wanted. Seasonal rainfall an immense quantity of brain water must necessarily runoff the ground. The collection of water and proper utilization is more importance. Such as e.g., water harvesting.

81. Use G.P.S Techniques to avoid chaos at disaster.

82. First and very elementary step in comprehensive planning.

83. The legal economically and political procedures necessary to implement ecosystem management; better scientific basis for comprehensive planning.

84. Mankind can do almost anything to provide he does not break natural laws in the process.

85. Pest Resistances crop losses from insecticides can be huge and crippling resulting financial loss for farmer and starvation. Much Fertilizer we used and lot Water for Crop we Use?

86. Fungus fight for malaria a tiny fungus called Metarhizium Anisopliae could become the next weapon to fight malaria. Which killed more 200,000 people in India? Every year this fungus naturally infects mosquitoes but unlike pesticides take days to kill them. The fungus M. anisopliae has no effect on human and that mean it could be safely released in large scale malaria control efforts... Dumped drug led to resistant microbes.

87. Proper waste management on the basis of degradable waste and non-degradable waste and proper recycle and ban polythene and plastic. And Use Jute and a cotton Bag.

88. Agricultural discharge in river must treat properly to reach into water bodies. Protect biodiversity as animal and herbal plant.

89. Fertilizer could apply carefully in term's proper dose in time and observing pre and post application precaution for complete utilization. Fertilizer destroys fertility rate. Because the organic matter in the soil is not replenished by the fertilizer used.

90. Promote organic farming system, minimum use of chemical and fertilizer, herbicides, pesticides etchant with a maximum input of organic manures recycled from bio- disposal waste (straw and live stick, excreta). culture of blue algae in preparation of bio fertilizer.

91. Neem leaves or turmeric; especially in grain storage as bio pesticides with healthy cropping system are beneficial insect, pest and wheat control besides providing nutrients.

92. Research on renewable resources less expensive chemical industries.
93. Research on renewable, resources, synthetic fibers.
94. Promote panchwati concept special research by Dr. Pradeep Srivastava from CDRI Pune show that peepal, banyan, neem, bail, Ashoka are high oxygen emission rate in day time approximate 1800 kg/hour for (peepal, Banyan tree). Large plantation on area of govt. private building cope with Climate change, Co2 emission.
95. More innovation and cheaper technology use it
96. Conservation of biological diversities.
97. You can believe to achievable you can control destination.
98. Greener and Cleaner project, use of plastics and polythene make pollution recycle it in proper manner.
99. Local Authorities should be the building of sewage systems and treatment stations so that to stop the discharge of waste waters directly in to streams. In case of the already existing treatment stations emphasize will be put on their modernization and specially on the capacity increase.
100. Our Body made from panchtatva (Five Matter) 1. Space (Vision,) 2. Earth Application of Knowledge), 3 Air (imagination), 4. (fire) span of Knowledge gained) 5. Water (assimilation of Knowledge).
101. Use phosphate solubilizing bacteria to save P-chemical fertilizers Azosprillium, Azotbactor, Rhizobium to save N- Chemical fertilizers and potash mobilizing bacteria to reduce to save K-chemical fertilizers and those can supplement about 20% P, N, and respectively. Dr. Krishan Chandra ADC (INM).
102. Integrated Nutrient Management (INM), which includes Soil test based balanced and Judicious use of chemical fertilizers in conjunction with bio-fertilizers and organic manure like farm yard manure (FYM), Co post, etc. by this consumption of chemical fertilizers can be reduced. Dr. Krishan Chandra ADC(INM).
103. Use slow-release fertilizers like Neem coated Urea and Briquetted Urea in place of normal Urea. (Dr. Krishna Chandra ADC(INM).)
104. Rain Water seeps through the soil and Sand and collect above the non-porous rocks. This enhances underground water or ground Water
105. In recent year efforts to divert municipal wastes from certain lakes has demonstrated that cultural eutrophication can reversed in the sense that some lakes will return to less fertile condition with improved water quality (in term of Human use) when nutrients no longer pour into them. see (Edmondson 1968.).
106. remember 3 E formula for industry Efficiency(skill), energy, employment
107. Beware of bugs, blooms and biohazards
108. Increasing microplastic garbage in sea water which affect eco system of sea due to UV light may affect decreasing degradation; loss of Bacteria, Microbiota.
109. Challenges of clean Plastic garbage in sea and land are more serious problem than climate change. Global sea water loaded plastic garbage around 2.96 Lakh Ton. plastic garbage increase in sea water affect biodiversity increase loss of marine ecology.
110. Be aware of the symptoms of water Borne diseases, during and after rowing.
111. Be aware of the symptoms of water borne diseases and know that action to take.
112. Display Plastic posters in appropriate places (safety notice, Board, changing rooms, toilets etc.).
113. informing members of the dangers, avoidance, symptoms and treatment of water borne diseases.
114. Never drink water from river or lake.
115. If contaminated water has happened swallowed refer to year doctor with full details of the incident. only drink water from own Bottle. do not splash river or lake water on your face or body in order to cool down.
116. Maintain your immunization regime against Tetanus, also Hepatitis A, Hepatitis B, Polio, Typhoid and Dysentery.
117. Wash your Hands thoroughly and Shower if necessary, before eating or drinking.
118. Do not inter linkage river system it may cause serious inter water dispute, but use in very short river linkage in heavy flooded area such Bihar and U.P. it can solve problem of flooding.

Rain falls and availability of drinking water

Rain fall is not only little used by the city but causes expensive trouble in terms of storm sewer maintenance and flood damage. Only driest climate is runoff from Roof's or other artificial catch basins used for drinking purpose. It usually is cheaper for city to get its water from natural water shed. (Salterpauls. 1974.) onwards an ecology of the urban environment.) Natural water has pH between 6.5 to 8.5. Annual rainfall. Topographic factors influence

vegetation by producing variation in climate of geographical region such variation in climate due to factors give rise characteristics local or even micro climates thus the effect of Topographic factors effect on climate factors. Solar Energy abundant source of energy but dilute and low-quality energy resources can put such as heat up water and used as water purifiers. Rain water is not only little used by city but it causes expensive trouble in terms of storm sever maintains and flood damage. only direct climate is runoff from roof or other artificial catch basin used for drinking purpose. see (Abrams Charles et al 1965., Likens and Bormann 1974.) Have documented how pH of rain water falling over the industrialized area has decreased. (That is rain water has become more acid) during past two decades.

Climate Change of human Health

Health effects associated with climate change. Heat related illness and death from more frequent heat wave; a rise in asthma, illness due to air pollution higher rates of food prices and water related deficiency and increase direct and direct impact of extreme event like hurricane.

Ground water pollution due to sewage and chemical waste raw sewage is dumped into shallow soak pit this gives birth to cholera, hepatitis, dysentery etc.

Sun- Energy and Eco –System

The sun, which drives the water cycle, heats water in

oceans and seas. Water evaporates as water vapor into the air. Ice and snow can sublime directly into water vapor. Evapo transpiration is water transpired from plants and evaporated from the soil. Rising air currents take the vapor up into the atmosphere where cooler temperatures cause it to condense into clouds. Air currents move water vapor around the globe, cloud particles collide, grow, and fall out of the sky as precipitation. Some precipitation falls as snow or hail, sleet, and can accumulate as ice caps and glaciers, which can store frozen water for thousands of years. Snow packs can thaw and melt, and the melted water flows over land as snow melt. Most water falls back into the oceans or onto land as rain, where the water flows over the ground as surface runoff. A portion of runoff enters rivers in valleys in the landscape, with stream flow moving water towards the oceans. Runoff and groundwater are stored as freshwater in lakes. Not all runoff flows into rivers, much of it soaks into the ground as infiltration. Some water infiltrates deep into the ground and replenishes aquifers, which store freshwater for long periods of time. Some infiltration stays close to the land surface and can seep back into surface-water bodies (and the ocean) as groundwater discharge. Some groundwater finds openings in the land surface and comes out as freshwater springs. Over time, the water returns to the ocean, where our water cycle started. Different Processes

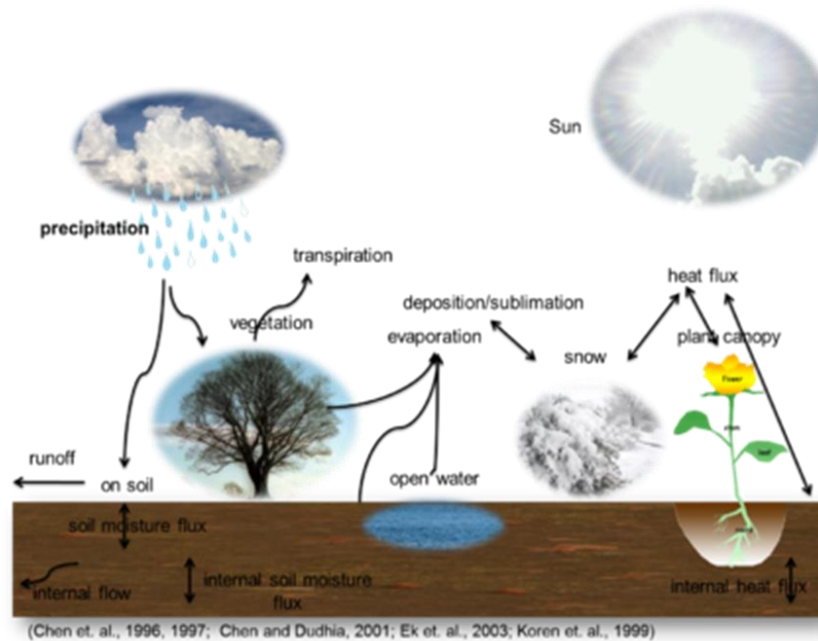

Fig 5: Sun and Water cycle

Solar energy in place fossil fuel requires a technology not developed direct conversion of sun light into electricity by means of solar cell is promising new

technology. We upgrade solar energy for higher level work make of natural efficient conversion namely photosynthesis for fuel as well as food. Has annual

growth of wood is managed fuel forest burned in wood geared steam electric pump. (Szego et al 1973.)

The Role solar energy as the driving force that pump water uphill as it were; and the enormously useful work done by water it runs downhill again. Due to this we emphasized that natural recycling of water is “free” and constitutes a vast. But almost on recognized use of solar energy. (by H.H. Odums 1970.) Has estimated that gallon of filtered clean water delivered to your home would cost two dollars if we had use. Solar fuel to recycle it with nature. Doing most of work water costs less than one dollar for a thousand gallons of water.

Sun is prime source of energy energy flows and material cycle on lands in the ocean in the air and in fresh water. Sun energy warm ecosystem and drives its internal water and mineral cycles. Solar radiation passes into atmosphere; the seas and green belt warms the biosphere of life –tolerable levels drive the hydrological cycle and powers the weather systems. So delicate are heat and others energy balances. Of the earth that meteorological models show that very small changes in solar constant or in turbidity of atmosphere are needed to change the world's climate. Just little decrease in heat brings on a little ice age, while a small increase brings tropical era, with melting of all the polar ice raising the sea level to flood large area of present continents. Energy loss in conversion of sun energy to plant matter. The dissipation of solar radiation as it passes in to the atmosphere and the sea and the green belt warms the biosphere of life tolerable levels drives the hydrological cycle and power weather systems. Due to solar energy of sun large volumes of air are purified daily, water recycled, climates-controlled weather moderated, and much other useful work accomplished.

Shallow water systems such as estuaries coral reefs and mineral spring together with moist forest intensive agriculture such as sugar cane production can crop on irrigated desserts. Large bodies of water are at disadvantage because a large portion of light energy may be absorbed by the water before reaches the site of maximum mineral supply in deep water.

The Sun, there is apparently no water, still there are living entities there. How does Cactus grow in desert, apparently without water? It gets water from the atmosphere the atmosphere contains all the element needed to sustain life: Earth, water, fire, air and ether. All these elements are present. The creation of the material Universe is like growth of great Banayan

Tree from tiny seed, no one can see the tree within seed, but all the necessary ingredients for Tree are there, including the required intelligence. A. C. Bhaktivedanata Swami Prabhupada,1973)

Impact of Mineral Nutrient another chemical component

The impact of mineral nutrients or other chemical components in an ecosystem. It is more important to know how fast material is moving along the pathways between organisms and environment. Due to excess use of fertilizer soil might contain a large amount of phosphorus, but if not available to organisms, perhaps because it is in an insoluble form then it might as well not be there.

Ecosystem having three components inorganic, organic and climate regime temperature and other physical factors that delimit the conditions of existence. In ecosystem temperature salinity and related chemical attributes of the body of water and the nature of sediments are major boundary conditions characteristics of the biosphere are series of gradients of physical condition. Shallow water ecosystem is occupied by mixture of macroscopic plants and macroscopic algae. Aquatic plants may become so great as to interfere with swimming boating and sport fishing; or un decomposed dissolved organic may impart a bad taste to water even after it has passed through water purification systems. Fertile green ponds capable producing many fish. (William et al 1968). Phytoplankton algae uptake by the plant is easily monitored by withdrawing and filtering small sample of water at interval over a period of several hours and counting sample as suitable detector decrease radioactivity of water. (Patrick Ruth 1953). When water pass through the city there are evaporate losses of water from natural ecosystem. Which match the consumption of water in the city resulting in lower output than input for both types' ecosystems? The waste water must be treated before discharge in to lake or river this would limit its nutrient input to stimulate bacterial multiplication reduced nutrient solubilized in water. To check recycle of nutrients in to water through harvest and removal of algal blooms upon death and decomposition. Effort to divert municipal wastes from certain lakes has demonstrated that cultural eutrophication can be reversed in the sense that some lake will return to less fertile condition with improved water quality in terms of human use. (Edmondson et al 1968)

NITROGEN FERTILIZERS

PHOSPHORUS FERTILIZERS

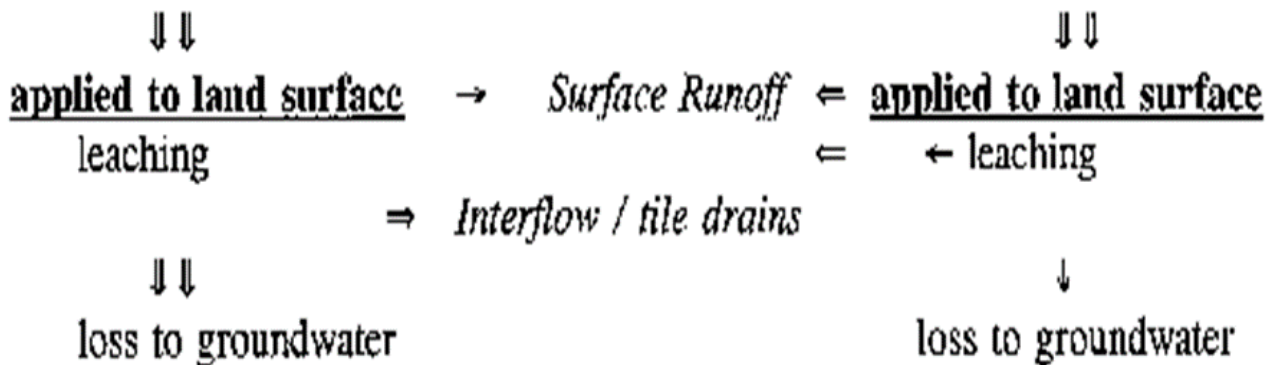

Fig 6: Loss of quality water due to organic farming

Water pollution and pollutant

Water may be polluted in many way

1. Sewage and other waste
2. Industrial effluent
3. agricultural discharge such as insecticides, fertilizer
4. Chemical industries

fossil fuel plant such as thermal plant, nuclear plant effluent discharge in river and sea they mixed with and availability of fresh water become so rare and they contaminated ground water also. each source of pollution carries variety of pollutants that enter our water bodies. Sewage is water borne waste derived from home domestic waste and animal or food processing waste. it includes human excreta, paper cloth, soap, detergent etc. major proportion of the pollutants entering our water and mixed our water and mixed with ground water. Safe drinking water provided through piped water supply system or hand pump and tube well.

Double food yield in the latter requires a tenfold increase in fuel fertilizers and pesticides (E.P Odum et al 1971). As Geographer M.G. Wolman 1971. Has concluded; "demand on water resources is increase at rate that exceeds the rate of installation of waste treatment facilities..."

Pollution Control Laws

Pollution has many ill effects on the environment whatever effluent is discharged in to river or lands it should be within permissible limit. specified by the pollution control board on agencies. Waste water is treated by capital investment and running cost by industries and disposing it in rivers streams and then it is used by someone else. to meet the quality standards of water and result it one way is to renovate

the treated waste water. All over world practice of reuse of treatment of waste water for agricultural and industrial purpose is followed. Ground water quality standards the chemical characteristics of ground water in the district have been analyzed by Central Ground Water (CGWB) from time to time. using treated was to water effluent as a water source for the creation and restoration of Wetland habitat for wild life use and environmental enhancement.

Waste Water Reuse

Waste water coming from kitchen and other area ideal for garden watering well treated grey water can also be reused for the purpose indoors for toilet flushing and clothes washing. reuse of waste water has many advantages such as reduce water bill, less depended on signal resources, reduction in pollution due to Waste water.

Result and discussion

Nitrogen, carbon dioxide and many other constituents along with phosphorous rapidly replace one another or growth promoting factors in translatory oscillation there no theoretical basis for any "one Factor" control hypothesis under transient – state condition. The strategy of pollution control must involve. Reducing the input of all enriching and toxic material not just one or two items. Water is prime natural resources fulfilling our needs in a precious assets. We must act to preserve and utilize every drop of water. Water resources can be assessed on the basis of surface and subsurface water bodies.

Climate change impact on ground Water the impact of climate change on ground water has been studied much less than the impact on surface waters. Ground water reacts to climate change mainly due to change in ground water recharge, but also change in river level in response to increase in mean Temperature,

precipitation, variability and sea level as mean precipitations. Changing land use pattern due to increasing, urbanization, industrialization and agriculture activities are serious issues that causing increase ground water with drawal resulting in depletion of ground water resources and mining of ground water resources, along with deterioration of water quality. Rainfall is highly irregular and erratic and declining year to year due to change climatic conditions as result of serious deforestation global warming etc. Human health is affected by change in biodiversity and ecosystem.

Physical factor affecting fresh water

1. Source of energy affecting ecological species.
2. Limiting factor since too little or too much to kill's
3. Extremely important regulator of daily and seasonal activates for great many organisms both plant and animal

Water conservation and Biomagnifications

Pesticides and bio pesticides can use in crop's production to enhancing production. pesticides are chemical used for killing the plant and animals DDT residues may found in air soil water and at several kilometer entered in ecosystem enter at lake ponds and river the contaminated the water. Then reach to zooplankton feeding on plant minnows eating zooplanktons then minnows eat by fish finally birds eat fish.

D.D.T. and chemical pesticides, insecticides are used in crop production may impact on chemical concentration increase food chain. One thing certain: man's competition with insects for food will continually require vigilance and change strategy, with reasonable control and coexistence a more attainable goal than complete elimination of pest (Dr. Robert Vanden Bosch.1970) Highly regarded entomologist has recently stated that "in all entomological history no broadly adapted insect widely established over diverse terrain has been eradicated through human effort". Science 184:112., H.H Koepf Soil Scientist Modern Agricultural can honestly claim only two notable crops disease and pesticides and third poison such as nitrogen fertilizer used soil enter our wells and pond's thus water rich with nitrates it is not only unfit for drinking but also cause disease. This water when taken by us the nitrate is converted to nitrates by microbial flora of instating. fresh water contaminated due to D.D.T., predatory Birds are Being Wiped out by D.D.T. Thousands of chemical pesticide has dilute with water has potential health hazards and turnoff of agricultural waste from excessive use pesticides and fertilizer can poison the

ground water and water supply which cause harm to environment. See. reference (Woodwell et al 1967. Toxic substance and ecological cycle Sci Amer 216(3); 24-31

Return water from all consumptive use is necessary polluted with number of chemicals that totally alien to rivers, lake, and estuaries' etc. Water pollution means that addition of any substance to changing water's physical and chemical characteristics is called water pollution it contains impurities such as dissolved as well as suspended particles. The poisonous substances reached at the food chain concentration were high enough to cause sickness and death physical and chemical and biological process may contributed.

DDT may be absorbed through skin of fish as well as ingested with food and water (drinking water).

Poisonous water produced by man such as insecticides and radioactive strontium all too often enter vital hydrological cycle and become lodged in tissue of animal and man.

Due to self-purifying ability of water is lost and water becomes unfit for drinking and other domestic uses. Since decomposition of sewage and other waste is largely an aerobic process accumulation of these in water increase it Oxygen requirement (B.O.D.).

B.O.D biological Oxygen Demand is amount of Oxygen required for biological Oxidation by microbes in any unit volume of water B.O.D value is amount of oxygen required for biological Oxidation Proportional to amount of organic waste present in water. E Coli index as parameter of water pollution. E Coli in unit volume of water due to addition of sewage of waste oxygen level are depleted which reflected in term of B.O.D value of water. B.O.D value are use full in evaluation of self-purification capacity of water body and possible control measures of pollution. B.O.D value indicated by kind of Organism present in water thus fish become rate at D.O. (dissolved Oxygen). D.O. level 4 to ppm of fresh water. Eutrophication is thus limiting factor in supply of clean water for drinking fishing and navigation etc.

Sewage and other waste in water result into

1. Depletion of Oxygen levels of water
2. Stimulation of algal growth.

(Hutcheinson et al 1948.) has shown that return phosphorous from sea to land as the result fish harvested by birds and man is of no small magnitude. Industries and mining have serious impact on availability of drinking water mining of Iron ore, Mica, Coal, Manganese, Lime stone etc. environmental impact of mining include loss production loss of top

soil surface, increase water pollution lowering Ground water level damage Vegetation soil drainage poor water quality.

Nature of atomic energy and its effect on water availability

Atomic energy used to generate electricity the fission or splitting of uranium with release energy and dangerous fission products such as radioactive substance strontium and cesium. Radiation effect due reactor disasters effect human and water resources lot. High temperature of water discharge from power plant is dangerous for human, animal, vegetation, and crop also. High temperature may cause algae to grow rapidly rendering unfit for consumption. Waste water from nuclear reactor and thermal power plant returned after use at very high temperature to stream of release hot water mixed with rivers, lake this which affect aquatic life in thus water bodies called thermal pollution. Hot water mixed with sea water has adverse effect on aquatic life. (Inglis et al, 1973) and Clark J.R. 1969. British Researchers find bottled water "less Safe 'Than Tap water – expert warn that bottled water is more likely to be contaminated or become a source of infection than tap water. People think there must be something wrong with tap water because it is so cheap and plentiful but from a safety and price perspective, tap water is better for you", (Professor Paul Younger of Glasgow University).

Source of water pollution

1. Underground water pollution
2. Surface water pollution
3. River water pollution
4. Sea water pollution
5. Air Pollution

Health and Environmental Effects of Ozone Layer Depletion

The Connection Between Ozone Layer Depletion and UVB Radiation

Reductions in stratospheric ozone levels will lead to higher levels of UVB reaching the Earth's surface. The sun's output of UVB does not change; rather, less ozone means less protection, and hence more UVB reaches the Earth. Studies have shown that in the Antarctic, the amount of UVB measured at the surface can double during the annual ozone hole. Another study confirmed the relationship between reduced ozone and increased UVB levels in Canada during the past several years.

Effects on Human Health

Laboratory and epidemiological studies demonstrate

that UVB causes nonmelanoma skin cancer and plays a major role in malignant melanoma development. In addition, UVB has been linked to cataracts -- a clouding of the eye's lens. All sunlight contains some UVB, even with normal stratospheric ozone levels. It is always important to protect your skin and eyes from the sun. Ozone layer depletion increases the amount of UVB and the risk of health effects.

EPA uses the Atmospheric and Health Effects Framework (AHEF) model, developed in the mid-1980s, to estimate the health benefits of stronger ozone layer protection policies under the Montreal Protocol. EPA estimates avoided skin cancer cases, skin cancer deaths, and cataract cases in the United States.

Effects on Plants

Physiological and developmental processes of plants are affected by UVB radiation, even by the amount of UVB in present-day sunlight. Despite mechanisms to reduce or repair these effects and a limited ability to adapt to increased levels of UVB, plant growth can be directly affected by UVB radiation. Indirect changes caused by UVB (such as changes in plant form, how nutrients are distributed within the plant, timing of developmental phases and secondary metabolism) may be equally, or sometimes more, important than damaging effects of UVB. These changes can have important implications for plant competitive balance, herbivory, plant diseases, and biogeochemical cycles.

Effects on Marine Ecosystems

Phytoplankton form the foundation of aquatic food webs. Phytoplankton productivity is limited to the euphotic zone, the upper layer of the water column in which there is sufficient sunlight to support net productivity. The position of the organisms in the euphotic zone is influenced by the action of wind and waves. In addition, many phytoplankton are capable of active movements that enhance their productivity and, therefore, their survival. Exposure to solar UVB radiation has been shown to affect both orientation mechanisms and motility in phytoplankton, resulting in reduced survival rates for these organisms. Scientists have demonstrated a direct reduction in phytoplankton production due to ozone depletion-related increases in UVB. One study has indicated a 6-12% reduction in the marginal ice zone.

Solar UVB radiation has been found to cause damage to early developmental stages of fish, shrimp, crab, amphibians and other animals. The most severe effects are decreased reproductive capacity and

impaired larval development. Even at current levels, solar UVB radiation is a limiting factor, and small increases in UVB exposure could result in significant reduction in the size of the population of animals that eat these smaller creatures.

Effects on Biogeochemical Cycles

Increases in solar UV radiation could affect terrestrial and aquatic biogeochemical cycles, thus altering both sources and sinks of greenhouse and chemically-important trace gases e.g., carbon dioxide (CO₂), carbon monoxide (CO), carbonyl sulfide (COS) and possibly other gases, including ozone. These potential changes would contribute to biosphere-atmosphere feedbacks that attenuate or reinforce the atmospheric buildup of these gases.

Effects on Materials

Synthetic polymers, naturally occurring biopolymers, as well as some other materials of commercial interest are adversely affected by solar UV radiation. Today's materials are somewhat protected from UVB by special additives. Therefore, any increase in solar UVB levels will therefore accelerate their breakdown, limiting the length of time for which they are useful outdoors.

Municipal Waste Impact on River Water System

Our environment is facing potential threat from un healthy waste disposal prevailing in almost all the urban centers in world. Though living standards has significantly changed the method of public health and sanitation still remain primitive. Vast quantities of waste generation by the cities one of the serious outcomes of unpleasant development from the point of municipal solid waste. Potential Vulnerable localities are demarcated for identifying the health affected areas. The most affected aquifer Zones are intensified through GIS application and being highlighted for future disaster mitigation action. one of the major problems of the city is improper disposal of municipal Waste. Urban population growth together with development of markets and new industries resulted in the quantum of a huge number of hazards organic and inorganic Waste daily. Proper Waste disposal is challenging issue that must addressed adequately. The source of waste is multiple and haphazard and disposal method is not scientific, as result of it; the environment is getting polluted day and day and gradually. The trace elements polluted the air, Water, soil and poses as a health risk to the people.

the terminology of solid waste is material, which is not liquid form and has no important to the person who responsible for it. although Human or animal excreta

which often end up in the solid waste stream. synonymous to Solid Waste are terms such as "garbage", "Trash", "Refuse", and "Rubish" C. Zurbrugg (2003): Swarup et al (1992) said that Waste is unavoidable consequences of satisfying man's need for food, water, air, space, shelter, and mobility, but all processes eventually produce same waste. the quantity of Solid Wastes attributed to rapid population growth, mass migration of population from Rural to Urban areas, floating population and increase in economic activities in city to gather with change in people's behavior for cleanliness. Solid Waste disposed in discriminately in the city, ultimately stands as a problem to civil society.it polluted the air, Water and Soil. In 1993, Misra and Mani said that solid wastes are unwanted materials disposed by man, which can neither flow in to stream nor escape immediately into the atmosphere. These non-gaseous and non-liquid residues result from various human activities. These cause pollution in water, soil and air. solid waste disposal poses a greater problem because it leads to land pollution if it is openly dumped, Citizen poses a greater problem because it leads to land pollution when dumped openly, water pollution if dumped in low lying areas and air pollution if burnt. water pollution if dumped in low-lying area and air pollution if it is burnt. the proper disposal of waste of any kind is essential for the precaution of the living environment and maintenances of high level of public hygiene. the effects on the environment of the treatment and disposal problem have to be taken in the best possible way to keep the city as a clean and healthy place for citizen finally at the core is "man". without the participation, cooperation and sense of responsibility belonging to Human being, it will be challenges to make in place livable, loveable and healthy.

How serious is our water challenge?

Lack of clean water is responsible for more deaths in the world than war. About 1 out of every 6 people living today do not have adequate access to water, and more than double that number lack basic sanitation, for which water is needed. In some countries, half the population does not have access to safe drinking water, and hence is afflicted with poor health. By some estimates, each day nearly 5,000 children worldwide die from diarrhea-related diseases, a toll that would drop dramatically if sufficient water for sanitation was available. It's not that the world does not possess enough water. Globally, water is available in abundance. It is just not always located where it is needed. For example, Canada has plenty of water, far more than its people

need, while the Middle East and northern Africa — to name just two of many — suffer from perpetual shortages. Even within specific countries, such as Brazil, some regions are awash in fresh water while other regions, afflicted by drought, go wanting. In many instances, political and economic barriers prevent access to water even in areas where it is otherwise available. And in some developing countries, water supplies are contaminated not only by the people discharging toxic contaminants, but also by arsenic and other naturally occurring poisonous pollutants found in groundwater aquifers.

Water for drinking and personal use is only a small part of society's total water needs — household water usually accounts for less than 5 percent of total water use. In addition to sanitation, most of the water we use is for agriculture and industry. Of course, water is also needed for ecological processes not directly related to human use. For a healthy, sustainable future for the planet, developing methods of ensuring adequate water supplies pose engineering challenges of the first magnitude.

Of course, by far most of the world's water is in the oceans, and therefore salty and not usable for most purposes without desalination. About 3 percent of the planet's water is fresh, but most of that is in the form of snow or ice. Water contained in many groundwater aquifers was mostly deposited in earlier, wetter times, and the rate of use from some aquifers today exceeds the rate of their replenishment.

"Overcoming the crisis in water and sanitation is one of the greatest human development challenges of the early 21st century," a recent U.N. report warns. (UN report)]

Where does our water supply come from?

From digging wells to building dams, engineers have historically been prime providers of methods for meeting the water supply and quality needs of society. To meet current needs, which increasingly include environmental and ecosystem preservation and enhancement demands, the methods will have to become more sophisticated.

One large-scale approach used in the U.S., China, India, and other countries has been to divert the flow of water from regions where it is plentiful to where it is scarce. Such diversion projects provide some short-term relief for cities, but do not appear practical as widespread, long-term, ecologically sound solutions, and this method generally will not be able to meet agricultural needs. Furthermore, diverting water to some people often means less for others and can become an explosive political issue.

What is desalination?

Desalination is extracting the salt from seawater. Desalination is not a new idea and is already used in many regions, particularly in the Middle East. Saudi Arabia alone accounts for about a tenth of global desalination. Israel uses desalination technology to provide about a fourth of its domestic water needs. Modern desalination plants employ a method called reverse osmosis, which uses a membrane to separate the salt. More than 12,000 desalination plants now operate in the world.

But desalination plants are expensive to build and require lots of energy to operate, making desalination suitable mainly for seaside cities in rich countries. It therefore has limited value for impoverished countries, where water supply problems are most serious.

New technologies that would lower energy use — and therefore costs — might help desalination's contribution. One potentially useful new approach, called nano-osmosis, would filter out salt with the use of tiny tubes of carbon. Experiments have shown that such tubes, called nanotubes because their size is on the scale of nanometers, have exceptional filtering abilities.

Even with such advances, though, it seems unlikely that desalination alone will be able to solve the world's water problems. Other approaches will be needed.

What other technologies will provide clean water?

Technologies are being developed, for instance, to improve recycling of wastewater and sewage treatment so that water can be used for nonpersonal uses such as irrigation or industrial purposes. Recycled water could even resupply aquifers. But very effective purification methods and rigorous safeguards are necessary to preserve the safety of recycled water. (Various nanotechnology approaches may be helpful in this regard, such as nanofiltration membranes that can be designed to remove specific pollutants while allowing important nutrients to pass through. [Hillie et al.,]). A different technological approach to the water problem involves developing strategies for reducing water use. Agricultural irrigation consumes enormous quantities of water; in developing countries, irrigation often exceeds 80 percent of total water use. Improved technologies to more efficiently provide crops with water, such as "drip irrigation," can substantially reduce agricultural water demand. Already some countries, such as Jordan, have reduced water use substantially with drip technology, but it is not a perfect solution for plant growth (e.g., it does not provide enough water to

cleanse the soil). Water loss in urban supply systems is also a significant problem.

Yet another strategy for improving water availability and safety would be small decentralized distillation units, an especially attractive approach in places where infrastructure and distribution problems are severe. One of the main issues is economical distribution of water to rural and low-income areas. Some current projects are striving to produce inexpensive distillation units that can remove contaminants from any water source. A unit smaller than a dishwasher could provide daily clean water for 100 people. Such approaches will help to address the very real problem of inequitable distribution of water resources. Even within a given country, clean, cheap water may be available to the rich while the poor have to seek out supplies, at higher costs, from intermediary providers or unsafe natural sources. Technological solutions to the world's water problems must be implemented within systems that recognize and address these inequities.

Harmful effects of Water Pollution

Human diseases. Pathogens are biological pollutants of water. They include viruses, bacteria, fungi, protozoan, helminths, nematodes, etc. they cause following diseases in human such as typhoid, Cholera, Dysentery, jaundice, and hepatitis.

Disturbances in ecological balance

All sorts of water pollutions affect the life-forms that are found in these water bodies in various ways. it can encourage the growth of some life forms and harm some other life –forms. This affects the balance between various organisms that persists in that system.

Removal of desirable substances from water bodies. with increase in the amount of organic wastes in water, the bacteria multiply rapidly and use up the available oxygen. lack of oxygen kills the fish and other animals. Biological Oxygen demands (BOD) indicates the quality of waste water. BOD refers to the amount of dissolved oxygens needed by bacteria in decomposing the organic waste present in water.

Effect of thermal pollution or change in temperature

Aquatic organisms are used to certain range of temperature in water-body where they live; a sudden marked change in the temperature would be dangerous for them, e.g., it affects breeding of aquatic animals. the eggs and larvae of various animals are particularly susceptible to temperature changes.

Destruction of useful micro-organisms

When untreated industrial wastes get mixed with water in rivers and lakes, etc., the acids, alkalis and heavy metals presents in the industrial wastes kill the use full organisms presents in water bodies.as these microorganisms are natural cleaning of water, therefore, self –purification processes are hindered in these water bodies.

Personal Responsibility Pollute Free Water

“Water, our most valuable resources keeping it clean.” take personal responsibility pollution free water resources. Every one's taken responsibility. Frequently, people make the mistake of think that the “Government” will take care of problem like water pollution. These people forget that we are citizen of nation. Our responsibility to eliminates water pollution from river resources.

How do We deal with Waste?

Despite our increasing efforts: - there is no completely safe way to get rid of our garbage, all methods of disposal come with high environmental price tags. the best solution for garbage problems is to make less shift and then find the most appropriate way to manage what lefts. use six formula we dispose waste tin six way

Reduce—Reuse---Recycle--Compost----Burn—Burry

Reducing what we create: - buy and use, what we throw out is most important step in saving our natural resources, energy, green space and reducing pollution.

What we Choose?

To buy and how it is packaged has a lot to do we throughout. we need to change our consumer habits and think twice before we buy so that we don't create more garbage.

Reuse

Most waste material are made from natural resources. Natural resources are things made from nature; such as trees, mineral, oil, gas and metals. The waste creates really a resource that is thrown away sometimes. After single use, keeps valuable materials out of landfills, and prevent pollution. When we reuse things, fewer materials are wasted and non-renewable resources are conversed.

The time has Come

The time has come for us to change our way of thinking; to place more value on the basic requirement for all life on earth-clean Air, Soil, and water-and reduces our waste to help protect them .we need to start taking action and change the way we

feel about and deal with waste as much as waste 80% of ever day waste materials can be recycled and given new life when broken down and used again and again.

Recycle still uses every and resources, don't have a recycling programming community?

Composites

Compositing is the oldest form of recycling different kind composites; some are designed for backyards and some for-apartment balconies; such as Vermicomposters; which use worms to accelerates the breakdown of food scraps in to soil.

Clean water Plant design and construct drinking water systems

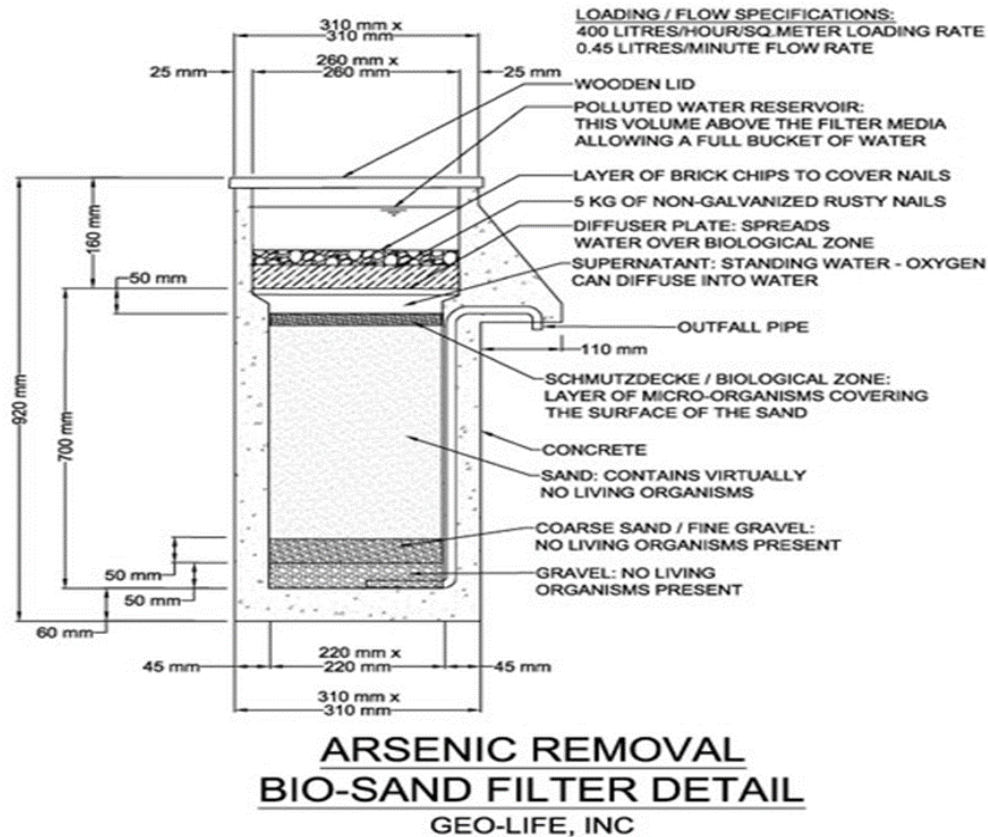

figure shows clean water Plant design and construct drinking water systems

Clean water Plant design and construct drinking water systems

As an example, our Arsenic Removal Filter Design is being used (free of charge) by more than 35 Nonprofits and NGOs around the world, to build filters in communities in rural areas where arsenic poisoning is a problem. Providing clean drinking water is what we have been trained for as civil engineers and planners. We have decades of experience in cleaning contaminated drinking water and stopping pollution from flowing to our water sources here in the United States. Now we are putting this expertise to work in developing countries where it is needed the most. On the average it cost about \$20 per person to build a water pump or water filter system in a community. These systems produce clean, safe drinking water for approximately 12 to 24 years. We work with partners in developing countries, to design and construct drinking water systems. With

our civil engineering / land use planning background we approach the problem with state-of-the-art designs and with realistic construction methods that can be easily implemented in the host country:

- Step 1: For immediate problems we provide filtering systems that are purposely designed and constructed to be simple. They are made from local materials so local people, who need filtering systems the most, can reproduce these filters on their own.
- Step 2: We install fresh water wells with hand pumps for entire communities, so no one has to go without clean water.
- Step 3: We investigate the causes of waterway pollution, which could be from industrial sources or local farms and ranches. Once we locate where the pollution is coming from, we design low-cost water treatment systems that are simple to build and effective. When toxic pollution flowing to local

waterways is stopped, entire communities will benefit with clean rivers, lakes and streams. The

health of everyone connected to these waterways improves.

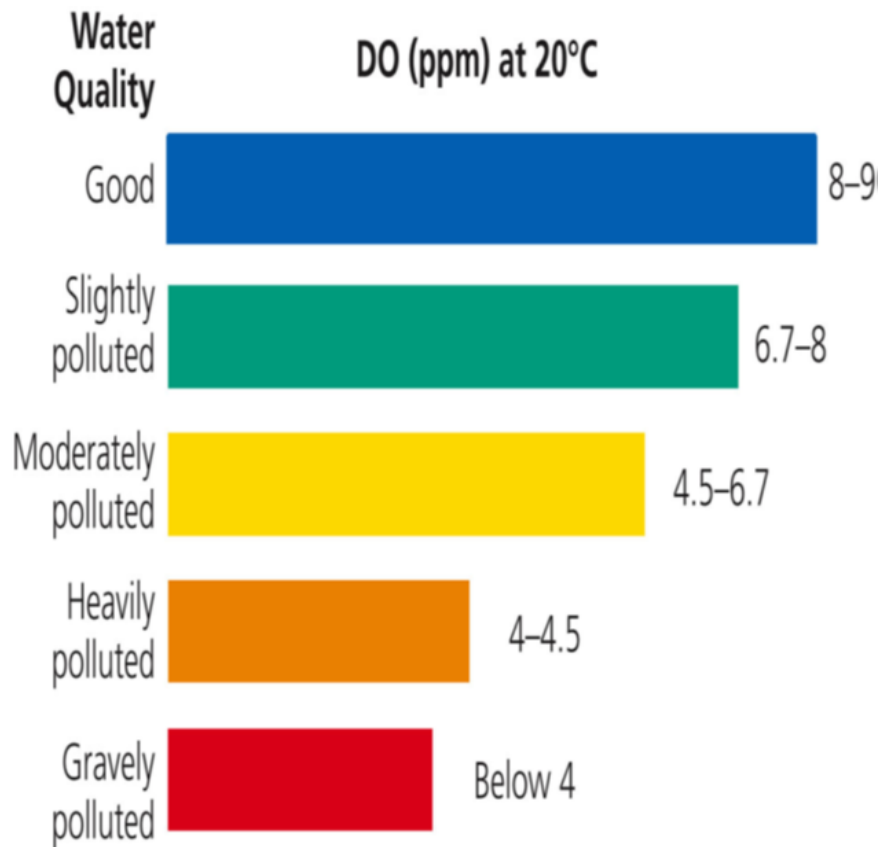

Mitigation Value to society

Mitigation creates safer communities by reducing losses of life and property

Mitigation enables individual and communities to recover more rapidly from disaster

Mitigation lessens the financial impact of disaster on government and communities.

Floods: - are temporary invadation of large regions as result of an increase in reservoir or of in rivers flooding their banks. Because of heavy rains high winds cyclones storm surge along coast. tsunami, melting of snow of dam burst.

Drought

drought is a climatic anomaly characterized by deficient supply of moisture resulting either from subnormal rainfall erratic rainfall distribution higher water need or combination of all factors.

it effects often accumulates slowly over a considerable period of time and may linger from month to year after the termination of the event.

Drought Monitoring

Monitoring and early warning essentially provides the foundation on which timely decisions can be made by decision maker at all levels (i.e. Farmer to national

Policy makers)

Land Use planning

Livelihood Planning

Crop Insurances (this is an insurance given to farmer who have lost their crops because lack of Water supply.

Garbage to Garden

Garbage to Garden to make vermicompost dig a pit in a nearby garden or take a trough with some soil in it. Put some vegetable peels and water on it. leave red worms, a type of earth worm and are the best for making compost on this waste cover the pit or through with the soil. sprinkle some water on it every day to facilitate decomposition after few days we will notice that the soil and vegetable waste have mingled and wonder full Manure is ready for Plant. This methods of preparing compost with the help of red worms is called vermicompost.

Water is prime natural resources fulfilling our needs in a precious asset. We must act to preserve and utilize every drop of water. Water resources can be assessed on the basis of surface and subsurface water bodies. Climate change impact on ground Water the impact of climate change on ground water has been studied much less than the impact on

surface waters. Ground water reacts to climate change mainly due to change in ground water recharge, but also change in river level in response to increase in mean Temperature, precipitation, variability and sea level as mean precipitations. Changing land use pattern due to increasing, urbanization, industrialization and agriculture activities are serious issues that causing increase ground water withdrawal resulting in depletion of ground water resources and mining of ground water resources, along with deterioration of water quality. Rainfall is highly irregular and erratic and declining year to year due to change climatic conditions as result of serious deforestation cause global warming.

The water cycles

Human activities can affect water quality as it passes through the water cycle. Water is our most recycled resources. the amount of water on earth is basically constant, but the distribution of water changes over time and space due to a dynamic process called water cycle or hydrological cycle. The water cycle is powered by solar energy and gravity. Our planet warmth from the sun causes evaporation of water from lakes; streams and soils. solar energy also drives a process called transpiration-the release and evaporation of water from tiny pores in leaves of plants. Evaporated and transpired water vapor is stored in the atmosphere until it condenses and is pulled by gravity back to earth as rain, sleet, snow, hail, dew or frost up to 80 % of this precipitated water is returned directly to atmosphere by evaporation. the rest many runoffs over land and into lakes and stream or may soak up into the ground.

Some of the water that soaks into ground stay in unsaturated zone. this zone is rock or soil layer in which some of the space between particles are filled with air and some are filled with water, some of the water is the unsaturated zone is taken up by plant roots and returned to the atmosphere by transpiration. the rest of water is pulled deeper into ground by gravity, filling all the causes and space in the underlying layers of soil, gravel and rock. Water in saturated zone called ground water. The top of the saturated zone is the water table. Water continues to move underground from area of high elevation toward low land areas. This movement is generally slow from few feet per day to few feet per year. Wherever the water table meets the land surface a spring may form or ground water may seep in to lake, stream; the water can evaporate and return to the atmosphere; and the water cycle begins again.

human activities may affect the quality of water at any point in the cycle. Air pollution can change the

chemical composition of rain and snow. runoff from rain fall and snow melt can pick up soil. excess plant nutrients, pesticides, animal waste and municipal and industrial pollutants as it flow over land into lakes and streams. contaminated runoff can also soak into the ground and pollute – ground water. Water percolating through soil and rock may pick up natural or other contaminants. Knowledge of the water cycle can help us understand water pollution and pollution can prevented.

Our water budget

a water budget similar to house hold financial budget,can be developed to track water movement through hydrological cycle. The receipts” are water coming into the drainage basin or water shed; and consist of the precipitation that falls within the basin as rain or snow. glacier created our aquifers.

the “disbursements” consist of water vapour released by evaporation or by transpiration from green plants and the water that is carried away into stream and river as runoff.

Source of ground water contamination

Ground water can become contaminated from natural sources or numerous types of human activities. Residential, municipal, commercial, industrial and agricultural activities can all affect ground water quality.

contaminants may reach ground water from activities on the land surface such as release or spills from stored industrial wastes; from source below the land surface but above the water table such as septic systems or leaking underground petroleum storage systems; from structures beneath the water table, such as wells; or from contaminated recharge water.

contaminants may reach ground water from activities on the land surface.

Use of pesticides and fertilizers

Millions of tons of fertilizers and pesticides (e.g., herbicides, insecticides, rodenticides, fungicides, avicides) are used annually FRO crop production some pesticides remain in soil and water for many months to many years. A number of these pesticides and fertilizers (some highly toxic) have entered and contaminated ground water following normal, registered use.

Effects of ground Water Contamination

contamination of ground water can result in poor drinking water, loss of water supply, degraded surface water system, high cleanup costs, high cost for alternate water supplies and /or potential health

problem.

Septic Systems

One of the main causes of ground water contamination in the effluent (out flows) from septic tanks, cesspools and priries septic systems that improperly sted, degined, constructed or maintained can contaminate ground water with bacteria viruses, nitrates, detergents, oils and chemicals along with these contaminants are the commercially available septic systems cleaners (containing trichloroethane or Methylene chloride). These cleaners can contaminate water supply well and interface with natural decomposition process in septic system.

Water conservation

- 1 turnoff the water when you are not using it don't let it run while you brush your teeth or shave.
- 2.Flash the toilet less often.
3. fix leaks and drips.
4. take shorter shower.
5. take bath.
6. keep a bottle of drinking water in the refrigerator
7. deep soak pit in your lawn.
8. Plant drought-resistant trees and plants.
- 9.promote rain water harvesting.
10. containing the contaminant to prevent migration
11. pumping of water, treating it, and returning it to the aquifer.
12. New well head protection ordinance.
- 13.flexibility the key to success.

Water Borne diseases and Human Health

Leptospirosis

The risk of contrasting Leptospirosis from recreational water is very small, However the serious nature of the diseases is such that we must aware of the diseases is such that we must aware of the dangers and should take simple precaution to reduce the risk of infection. Leptospirosis in as infection caught through contact with infected animal urine (mainly Rodets; cattle, or Pig.).

The casual organisms can enter the body via cuts or abrasions of the skin or the lining of the nose, mouth, throat infections or Eyes. if flu like symptoms develop shortly after contact with water (1-3 weeks) then your doctor should be contracted and advised of the circumstances of exposure

Blue-Green Algae-cyanobacteria

cyanobacteria are commonly found in fresh and Brackish water driving mid to late summer. Algal

blooms can form during extended period of work, settled weather. Algal scums accumulated downwind on the surface of lakes and slow-moving water. the majority of blooms produce allergens and toxins have caused the death of animals. In human they can cause eye irritation; dermatitis and joints/pains or more seriously, gastro-enteritis, pneumonia, liver damage and certain neurological conditions.

Gastro-intestinal illness

The use of inland water will never to be risk free and it is essential that user is aware of the risks involved in using a particular stretch of water. Assessing the risk posed by water quality is difficult as condition is very substantially in very short space time, in general; the health risk will depend on the number in any particular body of water.

Hepatitis A

Hepatitis A is caused by virus present in faces and is therefore another condition that many be contracted from water contaminated with sewage.

the onset of hepatitis can be abrupt and symptoms include fever; jaundice and abdominal discomfort.

Mitigation

- 1.Be aware of the symptoms of water borne diseases during and after rowing.
2. Be aware of the symptoms of water borne diseases and know that what action to take.
3. Display Posters in appropriate places (safety Notice Board, Changing Rooms, Toilets etc.).
- 4.informing members of the dangers, avoidance, symptoms and treatment of water borne diseases.

Information about water Borne diseases

1. Never drink water from river or lake
2. If contaminated water has been Swallowed refer to your doctor with full details of t incident.
3. only drink from your own Bottle
4. do not splash river or lake water on to your face or body in order to cool down. maintain your immunization region against Tetanus, Hepatitis A, Hepatitis B, Polio, Typhoid and dysentery.
5. Maintain your Hands thoroughly and Shower, if necessary, before eating or drinking.

Floods: - Consequences of too Much water: Floods

In addition to water scarcity, the accumulation of too much water in too little time in specific area can be devastating to population and national economic. Floods also provide benefits to humans through maintance of ecosystem. Functioning such as sediments and nutrient inputs to new soil fertility in

floods plains, although floods primarily natural events, Human influences their frequency and severity. by converting natural landscapes to urban centers, deforesting, hillsides, and draining, wetlands, Human reduce the capacity of ecosystems and soils to absorb excess water back into the atmosphere, creating condition that promote increased runoff and flooding.

Anthropogenic effects on hydrological cycle

anthropogenic factors related to direct water use for human needs, with reservoirs construction all over the earth, are producing clear effects on evaporation and runoff within large river basins, for the whole earth, however, the total annual river runoff-total water withdrawal is 9% and water consumption is 5%. from the view point of possible human impact on the hydrological cycle, the most serious problems are associated with predicted anthropogenic changes in global climate due to higher concentrations of CO2 and other greenhouse gases in the atmosphere. A rise of global air temperature by several degrees may bring about obvious changes in all hydrological cycle. components in many regions of the world. this may have severe impacts on scio-economic development and environment.

Human activity inevitable affects: the environment it causes, in plant cover and natural landscapes, and transforms water system.by making different from human activity are gradually accumulating in water bodies, in soil and on the earths. In general, anthropogenic factors cause adverse qualitative characteristics of the environment, particularly from ever-growing contamination of the air, surface and sub surface water's, soils and sub soils and degradation of natural land scopes. These processes are well- known and have analyzed in numerous publications. Human cycle i.e., it can affect the regime and quantity of precipitations of the hydrological runoff on local, regional and global scales.

Human activity affects to ceratin extent all basic components of the hydrological cycle. precipitation, evaporation and river runoff. however, any change in any components change in hydrological cycle components greatly depends on the size of the area concerned. as a rule; the larger the territory the more stable the nature ratio between invidual components of the hydrological cycle.

There are many types of human activity which can affects the hydrological cycle on different physiographic conditions and time-space scales i.e., from local scales to global ones: according to the nature and scale of human impact on hydrological cycle components (precipitation, evaporation, runoff) all the factors of human activity may be combined into following group

Factors connected with transformation on the earth's land surface.

Environmental impact of climate Change

Sea level changes during 20th century the mean sea level rise based on tide gauge was between 1.0 and 2.0mm/yr.

S.N	Types	VolumeThous.CU.Cm.
1.	World Ocean	1,338,000
2.	Ground Waters	23,400
3.	Fresh water	10,530
4.	Soil Moisture	16.5
5.	Glacier/Permanent Ice	24,100
6.	Lakes(fresh)	91
7.	Wetlands	11.5
8.	Rivers	2.12
9.	Biological Water	1.12
10.	Atmosphere	12.9
11.	Ice inpermafrost	300
	Total Hydrosphere	1,386,000
	Total Fresh water	35,029

Table 3: Water Borne Diseases

Diseases	Number Of cases	Relationship to Freshwater Service
Diarrhea	4 billion	Water contaminated by human faces.
Malaria	300-500 million	Transmitted by Anopheles Mosquitoes.
Schistomiasis	200 million	Transmitted by aquatic mollusks
Dengue and dengue	50-100 million dengue	Transmitted by Aedes Mosquitoes
Onchocerciasis	18 million	Transmitted by black Fly.
Typhoid and Paratyphoid Fever	17 million	Contaminated Water, Food; Flooding.
Trachoma	150 million,6 million Blind	Lack of basic Hygiene
Cholera	14,000-184,000(UN/WWAP2003)	Water and Food contaminated By Human feces contaminated Water.

Fresh water availability is global challenge. if enhancing fresh water to preserve through rain water harvesting method. Pollution free in Himalayan glaciers. glacier is main source of fresh water. Conservation of fresh water Leak is important. take responsibility to every citizen to cutoff pollution level in cities. Use bicycle, promote clean energy source such as wind, solar, and nuclear energy sources. minimum utilization of energy. save energy. promote Radio broadcasting services in every city because radio is basic needs to educate people for cleanliness, and energy conservation, rain water harvesting program. use rain water harvesting method in every building in metro cities. Collect rain water in dig well to use for drinking purpose. Minimum utilization of chemical fertilizer,

use Innovative technology such as Herbal pesticides (make through the plant and tree), use cow urine, Neem, chilly, curds, use as pesticides and use as insect repellent because harmful chemical residue pollute groundwater. check pollution level of distributary river and main river. House hold pollution may well treat and reuse but chemical pollution may not reuse it must use in reuse industrial purpose or use radio construction to make building a road. Human thinking and knowledge may destruct the society because everyone throw garbage on another head. no one take responsibility to save mother planet free from pollution.

Conclusion

“Water, our most valuable resources keeping it clean” Personal Responsibility

Water pollution control is ever one’s responsibility. frequently, people make the mistake of think that the “Government”. Will take care of the problem like water pollution. These people forget we, as citizen are the ones that should eliminates water pollution. Water pollution change in water quality that can harm organisms or make water **unfit for human uses contamination with chemicals and excessive heat.**

Waste management: - waste management is the processes of treating solid waste and offer variety of solution for recycling items that do not belongs to thrash. garbage can used as valuable resources. Waste management dispose of the products and substances use in safe and efficient manner. waste management is the “generation, prevention, characterization, monitoring, treatment, handling, reuse and residual disposition of solid waste.’ there are various types of solid waste including municipal (residential, institutional, commercial) agricultural,

and special (health care, house hold. hazardous waste, sewage sludge)”.

Types of waste disposal: - there are eight major groups of waste management methods of them divided in to numerous categories. those groups include source reduction and reuse, animal feeding, recycling, composting, fermentation, landfills, incineration and land application.

you can use to start using many techniques right at home. like reduction and reuse. which reduce the amount of disposable material used?

Methods of waste disposable landfills: - the processes of waste disposal focus attention on burning the waste in the land. landfills are found in all areas. these processes used eliminates the odor and danger of waste before it placed in to ground.

Incineration: - incineration or combustion is type disposal method in which municipal solid wastes are burned at high temperature so as to convert them in to residue of this types of methods is that it can reduce the volume. decrease the space they take up and reduce the stress on landfills. This process is known as thermal treatment where solid waste materials are converted by incinerators in to heat gas, stream, and ash.

Recovery and recycle: - resources recovery is the processes of taking use ful discarded item for specific use. these discarded items are them processed to extract or recover materials and resources or convert them to energy in the form of useable heat, electricity or fuel.

composition: - composition is easy and natural bio-degradation processes that takes organic waste i.e., remains of plants and garden and kitchen waste and turn into nutrients. Rich food for plants.

How much money can a solar roof save you?

fitting Solar panel on your roof can eliminates electricity bill.

plenty of important things that you should know about waste management and dispose in order to ensure keeping environment safe. it is your choice as to how you will dispose of waste.

How do we deal with house hold and municipal waste today?

despite our increasing efforts there is no completely safe way to get rid of our garbage, all methods of disposal come with high environmental price tags. the best solution our garbage problem is to make less shift and then find the most appropriate way to manage what lefts.

Reduce-Reuse-Recycle-compost-burn –burry

Reducing Waste, we create

buy and use, what we throw out is the most important step in saving our national resources, energy, green space and in reducing pollution.

What we Choose

to buy and how it is packaged has a lot to do with how much garbage we throw out. we need change our consumer habits and think twice before we buy so that we don't create more garbage.

Reuse

most materials are made from natural resources. Natural are things made resources. Natural Resources are things made from nature; such as trees, mineral, oil, gas and metals. The waste creates really a resource that is thrown away sometimes. After single use, keeps valuable materials out of landfills, and present pollution. When we reuse things, fewer materials are wasted and non-renewable resources are conversed.

The time Come

the time has come for such us to change ourway of thinking;to place value on the basic requirement for all life on Earth-clean air,soil and water and reduces our waste to help protect them.we need to start taking action and change the way we feel about and deal with waste.

as much as

80% of ever day waste materials can be recycled and given newlife when broken down and used again and again. recycle still energy and resources, don't have a recycling program community?.

Composite

compositing is the oldest form of recycling different kind compositers; some are degined for backyards and some for-department balconies; such as Verm composters; which use worms to accelerates the breakdown of food scraps in to soil.

Waste Treatment Water

the most successful way to manage waste is not to produce it in the first place and this is the driving force behind the idea of waste minimization. firstly, reduce the amount of waste created. The reuse wastes, the recover (via recycling, composting or waste-to-energy facilities) and finally as last resort to dispose of waste to land fill.

Waste from consumer goods

1. Packaging and packaging waste.
2. disposal of PCB and PCTs

3. disposal of spent batteries and accumulates
4. the reusing, recycling, and recovering of motor vehicles
5. environmental problems of PVC
6. Waste disposal and electronic equipment.

Proper disposal of waste

The proper disposal of waste of any kind is essential for the prevention of the living environment and the maintenances of high level of public hygiene. The effect on the environment of the treatment and disposal of waste therefore have enormous significance on the maintenance of quality of life and measure to reduce the problem have to take in the best possible way to keep the city Clean as a Clean and healthy place for its citizens. Finally at the core is "MAN". Without the participation, occupation and sense of belonging of Human being it will be a challenge to make a place livable, lovable and healthy.

Testing Water for Pollutants

1. Coliform bacteria: **Escherichia Coli**,
2. Significant level of **dissolved Oxygen (DO)**.
3. Chemical analysis.
4. Indicator Species
5. Bacteria and yeast glow in the presences of toxic chemical
6. Color and turbidity of water.

What Is Water Pollution?

Pollution is word that hear almost every day in the news. Our society has produced many kinds of Pollution some are more dangerous than other. Scientist are constantly studying how the different types of pollution affect the environment. how it controlled. it can be reduced Pollution. when something is added to environment that makes it unclean or unsafe it is called Pollution. Water Pollution occurs when the water becomes over loaded with too much of one thing and the aquatic organisms cannot keep up with their cleaning responsibility some organisms may die and other may grow too fast. Petroleum Product such as oil, gasoline, enter the Water from ships and marine terminals, offshore oil rigs, runoff from parking lots, factories, oil dumping and other sources many of the worst pollution disasters have been due to the accidents involving oil rigs, pipeline or oil tanks.

Water Pollution Can cause Diseases

Water has been one of man's precious commodities throughout history. Water, although essential for life.is frequently squandered. Misuse of water

become problem during the industrial revolution when populated cities developed. Wastes from the homes and factories were discharged directly into rivers and streams near cities. Contaminated rivers became major threat to public health because they transmitted diseases.

Microorganisms are found in all natural water ways. They will multiply if there is enough food available and proper environmental conditions are main kind for organisms growth. In polluted Water stream microorganisms multiply very fast to consume all the organic pollution that is available.

Conclusion

control of pollution: - increasing dimension of pollution

the establishment world organization known as United Nation Environment Protection programme (UNEP). Government and private industries play vital role to introduce anti- pollution steps.as results, the concentration pollutants like sulfur dioxide and nitrogen oxide has been reduced in the atmosphere of the developed countries. The industrial community is learning that wastes can being profit and that it is cheap to recycle waste than to throw them out. Water pollution can be reduced by proper disposal of Sewage degrading of shallow rivers and stream, cleaning operations in lake effective filtration and chlorination of drinking water; restricting random disposal of factory wastes in rivers specially town steps.

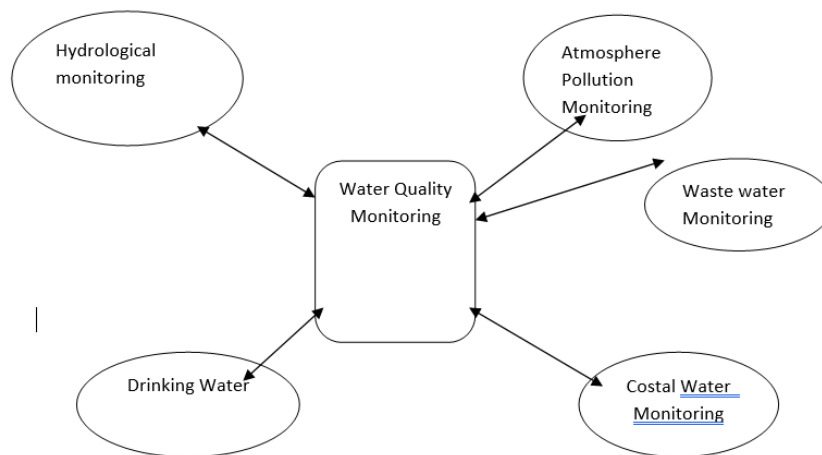

The inter relationship between major environmental Monitoring system (Rakesh et al 2014)

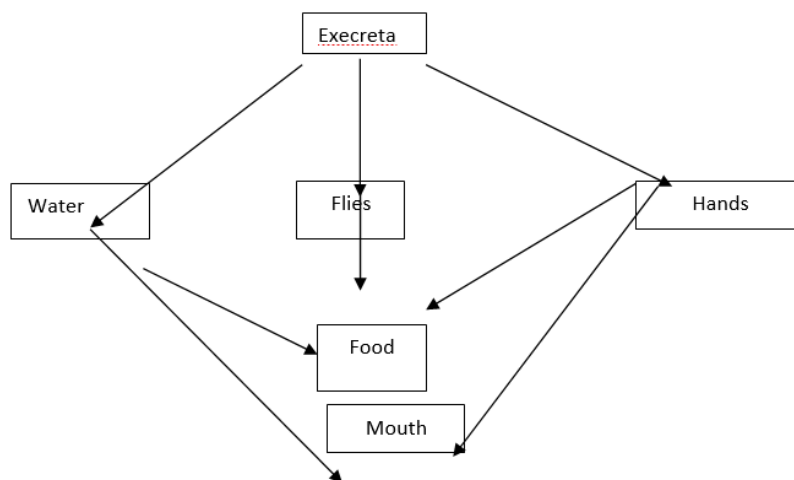

The Fecal-Oral Route of diseases Transmission (Rakesh et al 2014)

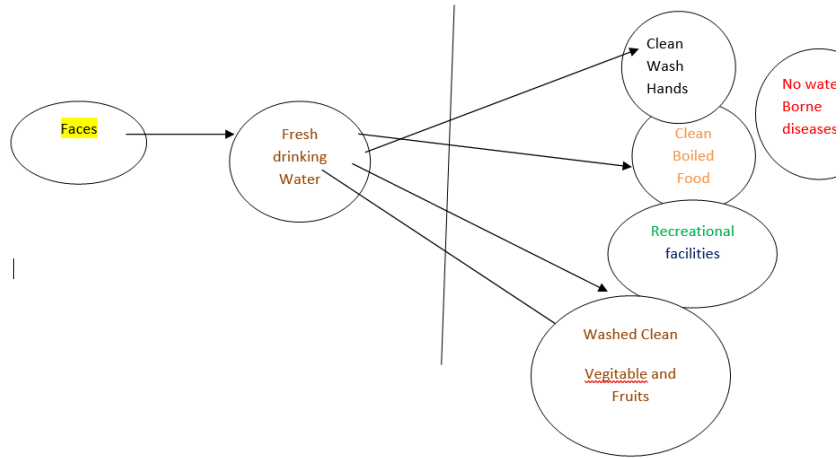

Protecting source water as a Barrier against Water Borne Diseases. (Rakesh et al 2014)

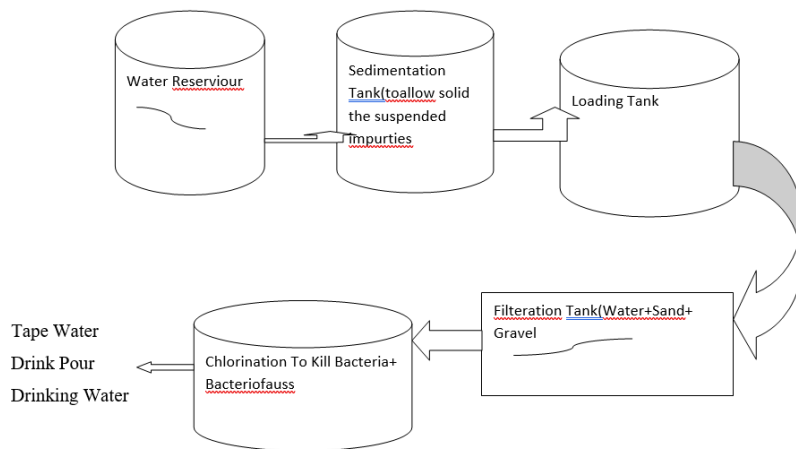

Water Purification System (Rakesh et al 2014)

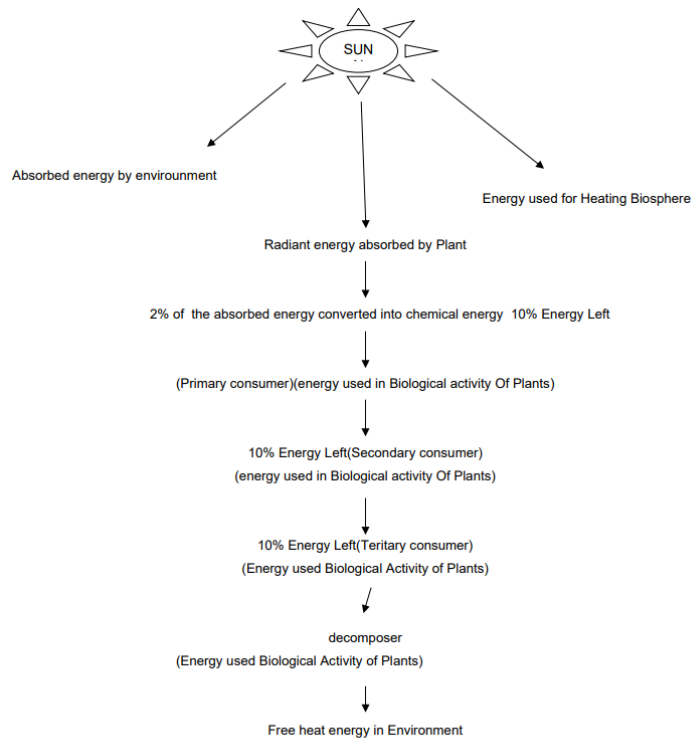

Electromagnetic energy from Sun (Rakesh et al 2014)

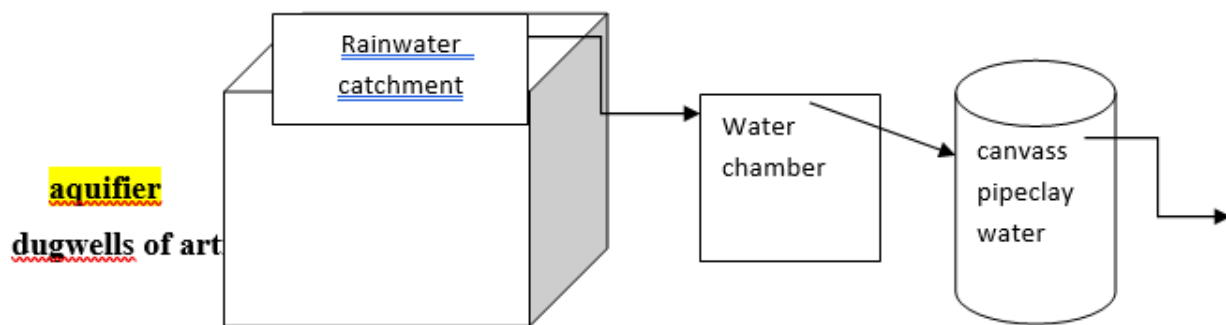

Rain Water Harvesting (Rakesh et al 2014)

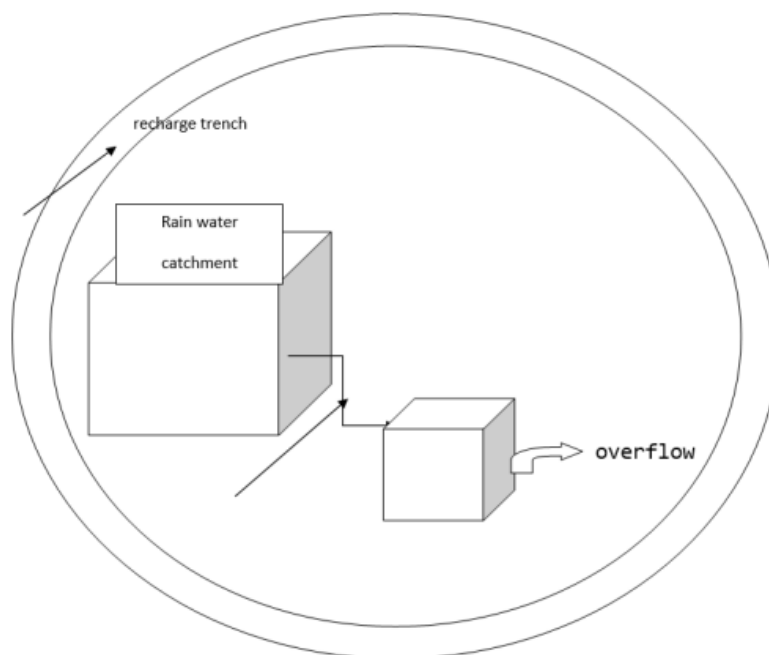

Rain Water In Metro Cities

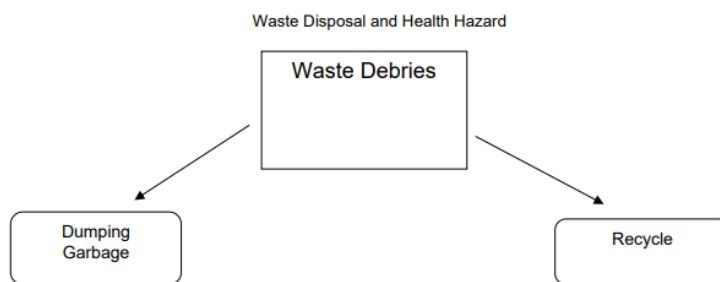

Rakesh et al 2015

Artificial recharge through hand pumps.

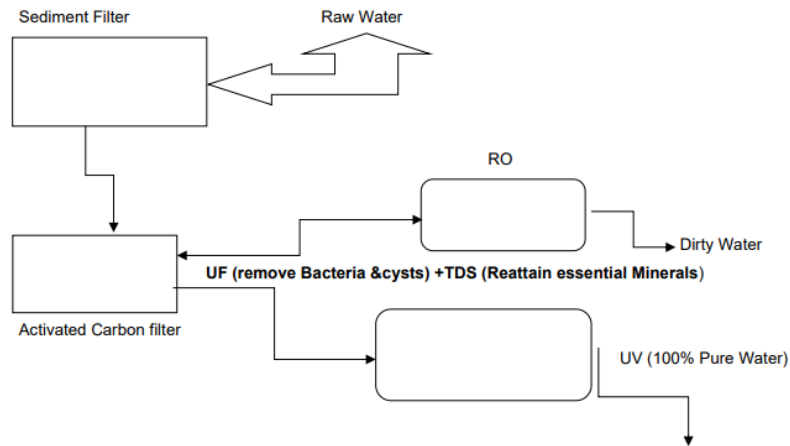

Kent Water Purifier Formula RO+UF+UV+TDS+100% Pure Water

References

1. "Climate Changes The water Rules" p.16-17.
2. "Global Warming & Climate Change Such Sea Water Rise" by R.K. Mishra abstract publish international Seminar Held at C.M.D. College, Guru Ghashidas Central University Bilashpur (C.G.), S.N.5B7, dated 6,7 October2009.
3. "Cause and effect of Climate Variability and Their Various Impacts" by R.K. Mishra and S.C. Dubey Research paper published in IOSR Journal of Environmental Science Toxicology and Food Technology (IOSR-JESTFT) ISSN:2319-2402, ISBN2319-2399. Volume1, Issue4 (Sep.-Oct.2012). pp 36-39.
4. "Climate Change and Cosmic Rays". Danish National Space Center".
5. A.C. Bhaktivedanata Swami Prabhupada, (Founder of the International Society for Krishna Consciosness)" Life Comes from Life".,1973
6. Alina Cocos.,Octavian Cocos .,Ioan Sarbu., "Coping with water Scarcity" Environ. Earth Sci. (2012).67:641-652.
7. AMAP,2002: (Arctic Monitoring and Assessment Program),2002: Arctic Pollution 2002: Persistent Organic Pollutants, Heavy metals, Radioactivity; Human Health,Changing pathways, AMAP, OSLO, Norway.
8. Beer, J., Mende, W., & Stellmacher, R. (2000). The role of the sun in climate forcing. Quaternary Science Reviews, 19(1-5), 403-415.
9. Benestad, R. E., & Schmidt, G. A. (2009). Solar trends and global warming. Journal of Geophysical Research: Atmospheres, 114(D14).
10. Bertram, P. E. (1993). Total Phosphorus and Dissolved Oxygen Trends in the Central Basin of Lake Erie, 1970–1991. Journal of Great Lakes Research, 19(2), 224-236.
11. Bhuiyan, M. J. A. N., & Dutta, D. (2012). Assessing impacts of sea level rise on river salinity in the Gorai river network, Bangladesh. Estuarine, Coastal and Shelf Science, 96, 219-227.
12. Bonvallot, V.,2003: L'arseni quotidien Biofutur,232, pp.70-3.
13. Boyer, D.,2001: Trade: The connection between environment and sustainable livelihoods working paper no.2 oxfam America Bostan,MA.
14. Bradley, D. (1977). Health aspects of water supplies in tropical countries. Water, wastes and health in hot climates, 3-17.
15. Bryson Reid A. 1974. A perspective on climate Change, Sci. Amer 184;753-760.
16. Bryson, R. A. (1974). A Perspective on Climatic Change: Climate responds rapidly and significantly to small changes of the independent variables. Science, 184(4138), 753-760.
17. C.Zurbrugg (2003):Solid Waste Management in developing Countries,SANDEC News,EAWAG,
18. Carpentar, S.R.,2003: Regime shifts in lake ecosystems: pattern and variation, excellence in ecology 15, International Ecology Institute, Oldendorf/Luke Germany.
19. Carslaw K.S.; Harrison R.G.; Kirkby J. (2002)." cosmic ray's Clouds and Climate" Science 298 (5599);1732-1737.
20. Chorus I. and Barttram, J. editors (1999) toxic cyanobacteria in water London E &FH spon.
21. Clark, J. R. (1969). Thermal Pollution and Aquatic Life. Scientific American, 220(3), 18-27.
22. Clean Water Life depends on it ! Fresh water

- series A-3., Environment Canada Ottawa,1992.
23. Cohen,M; 2003., Managing Boundaries: The case of the Colorado River Delta.In: The world Water: 2002-03,P.Gleick et al .(eds) Island Press Washington,D.C. pp.133-47.
 24. Confalonieri, U., Menne B., Akhtar, R., Ebi, K.L., Hauengue, M., Kovats, R.S., Revich, B. and Woodward, A., 2007, Human health. Climate Change 2007: Impacts, Adaptation and Vulnerability. Contribution of Working Group II to the Fourth Assessment Report of the Intergovernmental Panel on Climate Change. Cambridge University Press, Cambridge, UK, 391-431. *Cost Poison* 14;12-14
 25. Costa, M. H., & Foley, J. A. (2000). Combined effects of deforestation and doubled atmospheric CO₂ concentrations on the climate of Amazonia. *Journal of Climate*, 13(1), 18-34.
 26. Dai, A., Trenberth, K., and Qian, T., 2004, A Global Dataset of Palmer Drought Severity Index for 1870-2002: Relationship with Soil Moisture and Effects of Surface Warming. *Journal of Hydrometeorology*. (5). 1117- 1130.
 27. Douglas ,B.C. and Peltier , W.R. (2002) The puzzle of global sea – level rise. *Physics Today* 55 (3),35-41.
 28. Dr Krishan Chandra ADC(INM).
 29. Edmonson W.T. 1968 . Water- quality management and eutrophication: the lake Washington case in water resources management and public policy pp139-178. Seattle ;Univ.Of Washington Press.U.S.A.
 30. FAO (Food and Agriculture Organization of United Nations,1999: State of the World's Forest,FAO,Rome Italy.
 31. Fris-Christensen,E.,Froehlich,C.,Haigh,J.D.,Schlueser.,M. and Von Steiger,R., (eds) (2001) *Solar Variability and Climate*,Kluwer,Dordrecht,440 pp.
 32. George Brogstrom's book "Food for Man" 1967,1969.
 33. Gleick ,P.h.,(ed).(1993). *Water in crises* Oxford Univ. Press pp 473(problem on fresh water use in the world; statistical data on water resources socio-economic aspects of their use and results in different countries of the world.
 34. Gleick P.H., E.I. Chaleck: and A,Wong2002:Measuring Water Well-being Water Indicator and Indices,In: the World Water:2002-03,P. Gleick et al.(eds).Island Press,Washington D.C. pp.87-112.
 35. Gleick, P.H., et al. *The World's Water 2006-2007: Biennial Report on Freshwater Resources*. Chicago: Island Press.
 36. Gleick,P.H.(ed),1993: *Water In crisis: A guide to world's Freshwater resources*,Oxford University Press London U.K.
 37. Gleick,P.H., 1996:Basic water requirement for Human activities:Meeting Basic needs,*Water International*,21,PP.83-92.
 38. Gleick, P. H. (2000). *The world's water 2000-2001: the biennial report on freshwater resources*. Island Press.
 39. Gleick, P. H. (2002). *Dirty-water: estimated deaths from water-related diseases 2000-2020* (pp. 1-12). Oakland: Pacific Institute for Studies in Development, Environment, and Security.
 40. Goudie, Andrew, 2006, *Global Warming and Fluvial Geomorphology*. *Geomorphology*. (79). 3-4. 384-394.
 41. GWP(global Water Patership) 2000; *Integrated River Basin management, Technical Advisory Committee background paper*,Stockholm,Sweden.
 42. Hansen, J., Sato, M. K. I., Ruedy, R., Nazarenko, L., Lacis, A., Schmidt, G. A., ... & Zhang, S. (2005). Efficacy of climate forcings. *Journal of geophysical research: atmospheres*, 110(D18).
 43. Hathway, David H.; Wilson Robert M.(2004), "What the Sunspot Record tell's us about Space Climate" *Solar physics* 224(1-2);5-19.
 44. Hillie, T. et al. 2006. *Nanotechnology, Water, and Development*. Dillon, CO: Meridian Institute.
 45. Hilton, T. W., Najjar, R. G., Zhong, L., & Li, M. (2008). Is there a signal of sea-level rise in Chesapeake Bay salinity? *Journal of Geophysical Research: Oceans*, 113(C9).
 46. Holdren, J. P., & Ehrlich, P. R. (1974). Human Population and the Global Environment: Population growth, rising per capita material consumption, and disruptive technologies have made civilization a global ecological force. *American Scientist*, 62(3), 282-292.
 47. Huntington, T. G. (2006). Evidence for intensification of the global water cycle: Review and synthesis. *Journal of Hydrology*, 319(1-4), 83-95.
 48. Hutchinson, G. E. (1948). On Living in the Biosphere. *The Scientific Monthly*, 67(6), 393-397.
 49. Hutchinson, G. E. (1973). *Marginalia:*

- Eutrophication: The scientific background of a contemporary practical problem. *American Scientist*, 61(3), 269-279.
50. Vörösmarty, C., Askew, A., Grabs, W., Barry, R. G., Birkett, C., Döll, P., Goodison, B., Hall, A., Jenne, R., Kitaev, L., Landwehr, J., Keeler, M., Leavesley, G., Schaake, J., Strzepek, K., Sundarvel, S. S., Takeuchi, K., & Webster, F. (2001). Global water data: A newly endangered species. *Eos, Transactions American Geophysical Union*, 82(5), 54-58.
 51. English D.R. 1973 Nuclear energy It's Physics and It's Social Challenge massachusetts Univ. Press Addition Wesley Press.
 52. IPCC, climate change 2007: the physical science basis, in contribution of working group to the fourth Assessment Report of the Intergovernmental panel on climate change; slomon,s,qin,s; manning,M.,chen;Z.,marquis,M.,Averyt,K.B.,Tign ar,M., Miller;H.L.,Eds; Cambridge University press: Cambridge U.K.;Newyork,NY,U.S.A.,2007.
 53. Jensen, P. K., Jayasinghe, G., van der Hoek, W., Cairncross, S., & Dalsgaard, A. (2004). Is there an association between bacteriological drinking water quality and childhood diarrhoea in developing countries?. *Tropical medicine & international health*, 9(11), 1210-1215.
 54. Jensen,K.B.; K.H.,Ritters, J.D.,Wickham, R.D.Tankersdey, Jr., R.V.O'Neilly et al ., 1997: An ecological Assessment of United states mid – atalantic region:A land scape Atlas, U.S. Environmental Protection Agency Washington D.C.
 55. Konikow, L. F., & Kendy, E. (2005). Groundwater depletion: A global problem. *Hydrogeology Journal*, 13, 317-320.
 56. L'Vovich,M.I. and G.F. White,1990: use and transformation of terrestrial Water systems,In: the Earth as transformed by Human action,B.I. Turner,W.C. Clark,R.W.kanes Cambridge University Press,Cambridge LondonU.K. pp.235-52.
 57. Lamb, H. H. (1970). Volcanic dust in the atmosphere; with a chronology and assessment of its meteorological significance. *Philosophical Transactions of the Royal Society of London. Series A, Mathematical and Physical Sciences*, 266(1178), 425-533.
 58. Lean, J. (2000). Evolution of the Sun's spectral irradiance since the Maunder Minimum. *Geophysical research letters*, 27(16), 2425-2428.
 59. Lean, J. L., Wang, M., & Sheeley, N. R. (2002). The effect of increasing solar activity on the Sun's total and open magnetic flux during multiple cycles: Implications for solar forcing of climate. *Geophysical Research Letters*, 29(24), 77-1-77-2.
 60. Lean, J., & Rind, D. (2001). Sun-climate connections. *Earth's response to a variable Sun. Science (New York, N.Y.)*, 292(5515), 234–236.
 61. Lean, J., Beer, J., & Bradley, R. (1995). Reconstruction of solar irradiance since 1610: Implications for climate change. *Geophysical Research Letters*, 22(23), 3195-3198.
 62. Lock wood, Mike; Claus Frohlich. "Recent oppositely directed trends in Solar Climate Forcing and the Global Mean Surface Air Temperature " *Proceedings of the Royal Society A* 463:24447.
 63. McIntosh,A.C. and C.E.Yniquez,1997:second Water Utilities Data book,Asian Development Bank; Manila Philippines 210 pp.
 64. Meier, M. F., & Wahr, J. M. (2002). Sea level is rising: Do we know why? *Proceedings of the National Academy of Sciences*, 99(10), 6524-6526.
 65. Meybeck, M. (2003). Global analysis of river systems: from Earth system controls to Anthropocene syndromes. *Philosophical Transactions of the Royal Society of London. Series B: Biological Sciences*, 358(1440), 1935-1955.
 66. Meybeck,M.R.,Helmer,M.Dray,H.Elghobary,A.D emayo et al., 1991:water Quality:progress in the implementation of the mardel platu action plan,UN conference on water,Dublin,WHO/UNEP.
 67. Nearing, M. A., Jetten, V., Baffaut, C., Cerdan, O., Couturier, A., Hernandez, M., ... & Van Oost, K. (2005). Modeling response of soil erosion and runoff to changes in precipitation and cover. *Catena*, 61(2-3), 131-154.
 68. Newell R.E. the globel circulation of atmosphereic pollutant 1971 *Sci. amer* 224(1);32. see ref-NichollsR.j.; Cazenave,A.Seallevel rise and impact on costal zone,science 2010,328,1517-1520.
 69. Novick Sheldon 1974 . Nuclear reactor breeder environment 16;6-15 ; Critical of atomic energy

- commissions crash programme which according to analysis NRC 1999.
70. Odum H.T. 1970. Energy value of water resources proc. 19th southern water res. And pollution control conf, Duke Univ. press pp.56-64.
 71. Odum H.T. 1971. environment power and society New York; John wiley & sons.
 72. OECD(Organization for Economic- Co-operation and evelopment,1999: The price of water: Trends In OECD Countries.OECD paris,France.
 73. Oki, Taikan and Shinjiro Kanae, 2006, Global Hydrological Cycles and World Water Resources. Science (313): 5790. 1068-1072.
 74. Patrick, R., Gaufin, A. R., & Tarzwell, C. M. (1953). Aquatic Organisms as an Aid in Solving Waste Disposal Problems [with Discussion]. Sewage and Industrial Wastes, 25(2), 210-217.
 75. Plass, G. N. (1959). Carbon dioxide and climate. Scientific American, 201(1), 41-47.
 76. Postel, S. L. (1998). Water for Food Production: Will There Be Enough in 2025? BioScience, 48(8), 629-637
 77. Postel, S. L., Daily, G. C., & Ehrlich, P. R. (1996). Human appropriation of renewable fresh water. Science, 271(5250), 785-788.
 78. Prof Kan Shaozhong- Director of Center of Agricultural Research in China.
 79. Professor Paul Younger of Glasgow University).
 80. R.Swarup,S.N.Misra and V.P. Jauhari(1992):in Encyclopedia of Ecology,Environment and pollution Control-9,Mittal Publication New Delhi.
 81. Ramanathan, V., & Feng, Y. A. N. (2008). On avoiding dangerous anthropogenic interference with the climate system: Formidable challenges ahead. Proceedings of the National Academy of Sciences, 105(38), 14245-14250.
 82. Reynolds E.R.C. and Thompons F.B.,(eds).(1988). Forests, climate and hydrology, Regional impacts, the U.N. University, Tokyo Japan pp 217(a set of paper on the affects of forest and forestry on hydrological cycle components in different regions).
 83. Rind, D. (2002). The Sun's role in climate variations. Science, 296(5568), 673-677.
 84. S.G. Misra and D.Mini(1993):Pollution through Solid Waste,Ashish Publishing House,New Delhi.
 85. Svensmark, H. (1998). Influence of cosmic rays on Earth's climate. Physical Review Letters, 81(22), 5027.
 86. Shiklomanov, I. A., & Rodda, J. C. (Eds.). (2003). World water resources at the beginning of the twenty-first century. Cambridge University Press.
 87. Shri Mahesh Gupta Chairman kent RO system INDIA Ltd.
 88. Douglas, B. C., & Peltier, W. R. (2002). The puzzle of global sea-level rise. Physics today, 55(3), 35-40.
 89. Stark, P. (1994). Climatic warming in the central Antarctic Peninsula area. Weather, 49(6), 215-220.
 90. World Bank. (2007). Making the most of scarcity: Accountability for better water management in the Middle East and North Africa. The World Bank.
 91. U.S. Census Bureau, Population Division. International Programs Data. Accessed July 2007.
 92. McNicoll, G. (2007). United Nations development programme: human development report 2006. Beyond scarcity: power, poverty and the global water crisis. Population and Development Review, 33(1), 198-200.
 93. van den Bosch, R. (1970). Pesticides: prescribing for the ecosystem. Environment: Science and Policy for Sustainable Development, 12(3), 20-25.
 94. Vandam ,J.C.,ed(1999). Impacts of climate change and climate variability on hydrological regions. Cambridge University Press.140 pp.
 95. Vollenweider R.A. et al (1996) . Assesment of the state of eutrophication in Mediterranean sea.UNEP Athens.
 96. Water Scarcity index ,(2009.) In UNEP/GRID Arendal Maps and Graphics Library.
 97. World Commission on Dams. (2000). Dams and development: A new framework for decision-making: The report of the world commission on dams. Earthscan.
 98. Weinbergh A. M. and R.P..Hammand 1970. Limit to use of energy science. Amer 58;412-420.
 99. World Health Organization. (2002). The world health report 2002: reducing risks, promoting healthy life. World Health Organization.
 100. World Health Organization. (2004). The World health report: 2004: changing history. World Health Organization.
 101. Williams, C. M. (1967). Third-Generation Pesticides. Scientific American, 217(1), 13-17.
 102. Willson, R. C., Gulkis, S., Janssen, M.,

- Hudson, H. S., & Chapman, G. A. (1981). Observations of solar irradiance variability. *Science* (New York, N.Y.), 211(4483), 700–702.
103. Willson, R. C., & Hudson, H. S. (1991). The Sun's luminosity over a complete solar cycle. *Nature*, 351(6321), 42-44.
104. Wigley, T. M. L., & Raper, S. C. B. (1992). Implications for climate and sea level of revised IPCC emissions scenarios. *Nature*, 357(6376), 293-300.
105. WMO(World Metrological Organization),1997: comprehensive Assesment of the fresh water resources of world,UN,UNDP,UNEP,FAO,UNSECO,WMO, United Nation Industrial Development Organization World Bank,SEI,WMO Geneva,Switzerland.
106. Woodwell, G. M. (1967). Toxic substances and ecological cycles. *Scientific American*, 216(3), 24-31.
107. Woodwell, G. M., Wurster Jr, C. F., & Isaacson, P. A. (1967). DDT residues in an east coast estuary: a case of biological concentration of a persistent insecticide. *Science*, 156(3776), 821-824.
108. Woodwell, G. M. (1967). Toxic substances and ecological cycles. *Scientific American*, 216(3), 24-31.
109. Woodwell, G. M. (1970). Effects of Pollution on the Structure and Physiology of Ecosystems: Changes in natural ecosystems caused by many different types of disturbances are similar and predictable. *Science*, 168(3930), 429-433.
110. Woodwell, G. M., Wurster Jr, C. F., & Isaacson, P. A. (1967). DDT residues in an east coast estuary: a case of biological concentration of a persistent insecticide. *Science*, 156(3776), 821-824.
111. World Health Organization (WHO)/UNICEF Joint Monitoring Programme for Water Supply and Sanitation. 2005. *Water for Life: Making It Happen*. Paris: WHO Press.
112. World Water Assessment Programme. 2006. *Water: A Shared Responsibility: The United Nations World Water Development Report 2*. Paris and New York: United Nations Educational, Scientific and Cultural Organization and Berghahn Books.
113. WRI (World Resource Institute),UNEP,UNDP and World Bank,1998: World resources 1998-99. Environmental Change and Human Health , Oxford University Press Newyork U.S.A.
114. WWC (World Water Council),2000; World Water Vision Earth Scan London ,UK.
115. WWF and WRI (World Wide Funds Nature and World Resource Institute), 2004, *River at risk: Dam and Future of Fresh water Ecosystem*,WWF,SURREY,U.K.
116. Xu, L., Pan, J., Jiang, J., Zhao, H., & Liu, C. (2013). A history evaluation modelling and forecastation of water quality in shallow lake. *Water and Environment Journal*, 27(4), 514-523.
117. Yao Tandong, Director of the Chinese Academy of Science Insitute of Tibetan Plateau Research.
118. Yu; Y.F.; Yu, y. X. Zuo, J.G.; wan,Z.W., Chen,Z.Y. (2003), Effect of sea level variation on tidal characteristics value for the east China ocean .,17,369-382.